



Illustrated Parts List

AXIP-0057

November 2012

D170, D170D, R170, R170D - Single Reduction - Tandem Axles

D190, D190D, R190, R190D - Single Reduction - Tandem Axles

S170, S170D, S190, S190D - Single Reduction - Single Axles

S170E, S190E, S190DE - High Entry - Single Axles

D590, D590D, R590, R590D, S590, S590D - Double Reduction Axles

Table of Contents

How To Use Illustrated Parts List.....	2
Model Identification.....	3
Model Information.....	4
Single Reduction Model Line-up.....	5
Helical Double Reduction Model Line-up.....	5
Tridem Model Line-up.....	5
High Entry Single Axle Model Line-up.....	5
Forward Single Reduction Models - D170, D170D, D190, D190D - Carrier Exploded View.....	6
Forward Single Reduction Models - D170, D170D, D190, D190D - Power Divider - Exploded View.....	7
Forward Single Reduction Models - D170, D170D, D190, D190D - Parts List.....	8-10
Forward Double Reduction Models - D590, D590D - Carrier Exploded View.....	11
Forward Double Reduction Models - D590, D590D - Power Divider - Exploded View.....	12
Forward Double Reduction Models - D590, D590D - Parts List.....	13-14
Forward Double Reduction Models - S590, R590 / S590D, R590D - Carrier Exploded View.....	15
Forward Double Reduction Models - S590, R590 / S590D, R590D - Power Divider - Exploded View.....	16
Forward Double Reduction Models - S590, R590 / S590D, R590D - Parts List.....	17-18
High Entry Single Models - S170E, S190E, S190DE - Forward Carrier Exploded View.....	19
High Entry Single Models - S170E, S190E, S190DE - Forward Carrier Power Divider - Exploded View.....	20
High Entry Single Models - S170E, S190E, S190DE - Parts List.....	21-22
Rear-Rear Single Reduction Models - R170, R170D, R190, R190D, S170, S170D, S190, S190D - Carrier Exploded View.....	23
Rear-Rear Single Reduction Models - R170, R170D, R190, R190D, S170, S170D, S190, S190D - Parts List..	24-25
Pinion Bearing Selective Spacers.....	26
Wheel Differential Case Halves and Kits - All Single Reduction Models.....	27-29
Wheel Differential Lock - Shift Parts - Exploded View & Parts List.....	30
Wheel Differential Lock - Diff Lock Case Halves & Shift Fork Reference Charts - All Diff Lock Models.....	31-33
Axle Housing and Output Shaft Assembly - Exploded View.....	34
Axle Housing and Output Shaft Assembly - Parts List.....	35
Summary of Axle Housing Service Kits.....	36
Axle Housing Hardware Kits.....	36
Supplemental Bulletin Information - Output Shaft Bearing Component Change - October 2011.....	37
D170 Axle Housing Replacement Chart.....	38-39
D190 Axle Housing Cover Change / Axle Housing Cover Kit Listing.....	40
Axle Shafts.....	41-42
Bearing Kits.....	43
Supplemental Bulletin Information - Carrier Bearing Cup and Cone Change - February 2012.....	44
Bearing Part Number Supersession List.....	44
Input Adjuster & Cups and Output Side Gear & Lube Pump Effects.....	45-46
Output Shaft Bearing and Kit Effects.....	46
Service Carriers.....	47-54
Gear and Pinion Kits.....	55-56
Yokes & Flanges.....	57
Service Tool Kits.....	58
Pinion Seal Driver Tool Kit.....	58
Wheel Differential Bearing Adjustment Tool Kit.....	58
Spicer Service Kits Quick Reference Parts Listing.....	59-60

General Information

How To Use Illustrated Parts List

Ordering Parts

- This parts book is organized in sections according to parts servicing requirements. Use the Contents or page headings and colored tabs to find information.
- Use this book to order parts for your Dana® Spicer® Axle.
- For convenience, part numbers have been included for all pieces of the carrier assembly. Some of these parts, such as the carrier and caps, are serviced only in kits or assemblies. Part numbers are for your reference only. Those parts not serviced separately are identified with NSS.

Kits and Assemblies

- Kits and Assemblies contain groups of individual or assembled parts developed for optimal replacement or repair of a service problem.
- Kits and Assemblies are shown with applicable parts groupings in the parts listing.
- See the Appendix for detailed information concerning kits applicable to this model.

Abbreviations

- AR - As Required - Parts that vary in quantity with each axle. Example: shims
- NSS - Not Serviced Separately - Items which can only be purchased in sets, kit form or service assemblies. Example: brake shoes.
- RH/LH - Right Hand/Left Hand - Determined as viewed from behind the vehicle looking forward.
- "RTV" - Gasket Compound - Formed-in-place gasket sealer. It is recommended for use on all surfaces requiring a gasket.
- Assy - Assembly
- Brg - Bearing
- Diff - Differential
- Hsg - Housing
- Inv - Involute
- ABS - Antilock Brake System
- N/A - Not Applicable
- Str - Straight

Illustrations

- Illustrations show parts in assembly groups.
- Item numbers on illustrations correspond with parts listings on pages that accompany the drawings.
- Notes are included on illustrations where needed.

Parts Listings

- Parts listings are defined by parts groupings and are broken down by service assemblies.
- Parts Listings identify a part for servicing with the following categories:
 - Item - corresponds with numbers on illustrations for part identification
 - Part Name - specifies part name or description
 - Quantity (Qty) - quantity required for assembly
 - Current Part - service part numbers are broken down by model, type or other applicable information
 - Notes - define unique characteristics or replacement notes
 - Kits / Assy's Where Used - indicates Kits or Assemblies that contain a particular part
- ***Other pertinent information is listed in tables or parts listings as required.***

Model Identification

Locating Model Designation Information

- Axle Model Identification, Part Number and Serial Number are located on a tag at the axle centerline. This information will help to locate information in this book and to identify the correct parts for servicing.

Drive Axles

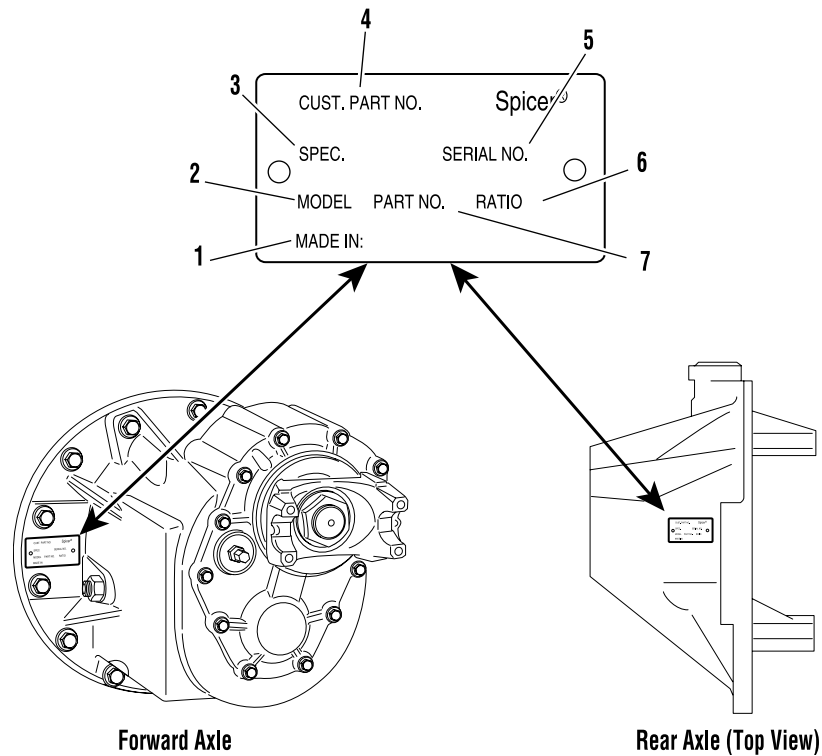

- 1 - Country or origin**
- 2 - Axle model identification**
- 3 - Specification number assigned to the axle built by Spicer. Identifies all component parts of the axle including special OEM requirements such as yokes or flanges.**
- 4 - OEM part number assigned to the axle build**
- 5 - Carrier assembly serial number assigned by the manufacturing plant**
- 6 - Axle gear ratio**
- 7 - Carrier assembly production or service part number**

Axle Housing

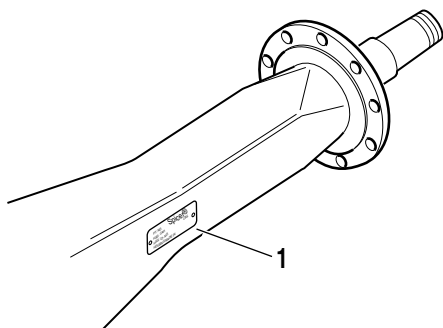

1 - ID Tag

Axle Shaft

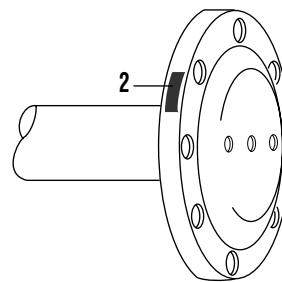

2 - Axle shaft part number

Using Model Designation to Identify Axle Components

The Axle Model Identification number contains information that is important to understand when purchasing service parts or new components. The Model Identification number provides important vehicle, capacity and application information and model features. Use this guideline to understand your Axle Model Identification. If you need assistance, contact your Dana Aftermarket representative.

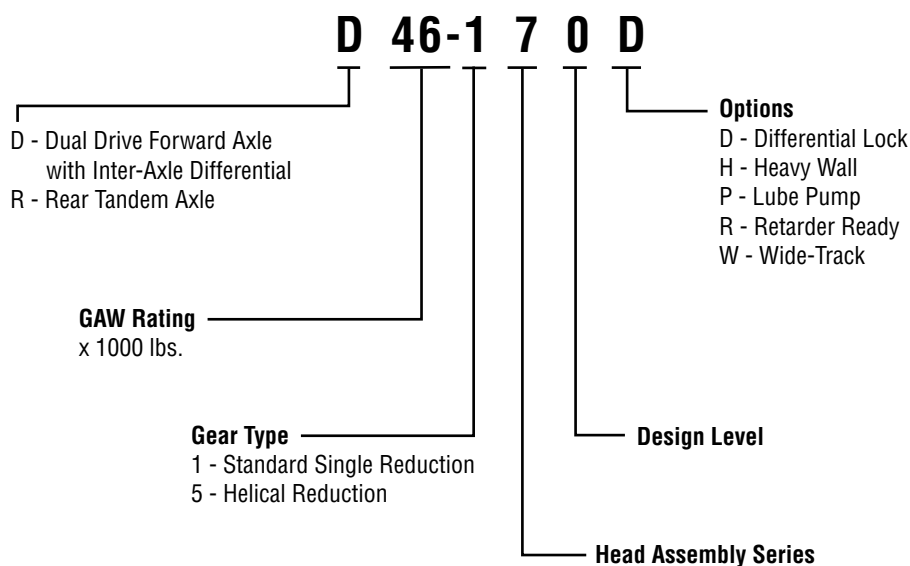

Effectively using a Parts Listing - Example

- Follow the example below to locate and order exactly what is required for servicing.

Match to items on illustration	Use to identify Part	Order this quantity for servicing	Order Part Number		Indicated information important to ordering or use
Item	Part Name	Qty	D170	D190(P)	Notes
1	Axle Shaft	2	xxxxxx	xxxxxx	See Axle Shaft Chart
2	Flat Washer	4	xxxxxx	xxxxxx	

Kits and Assemblies

Item	Part Name	Qty	D170	D190(P)	Notes
Bearing Kits		1	xxxxxx	xxxxxx	Contents Identified with *

Model Information

The following models are included in this publication:

Single Reduction Models

Forward Axle	Rear Axle	Axle Capacity	Gear Size
D40-170	R40-170	40,000 lbs.	17.7" Hypoid Gear
D40-170P	R40-170	40,000 lbs.	17.7" Hypoid Gear
D40-170DP	R40-170	40,000 lbs.	17.7" Hypoid Gear
D46-170	R46-170	46,000 lbs.	17.7" Hypoid Gear
D46-170P	R46-170	46,000 lbs.	17.7" Hypoid Gear
D46-170DP	R46-170	46,000 lbs.	17.7" Hypoid Gear
D52-190P	R52-190	52,000 lbs.	18.5" Hypoid Gear
D52-190DP	R52-190	52,000 lbs.	18.5" Hypoid Gear
D60-190P	R60-190	60,000 lbs.	18.5" Hypoid Gear

Double Reduction Models

Forward Axle	Rear Axle	Axle Capacity	Gear Size
D46-590P	R46-590	46,000 lbs.	18.5" Hypoid Gear
D52-590P	R52-590	52,000 lbs.	18.5" Hypoid Gear
D60-590P	R60-590	60,000 lbs.	18.5" Hypoid Gear
D70-590P	R70-590	70,000 lbs.	18.5" Hypoid Gear

Tridem Models

Forward Axle	Forward Axle	Rear Axle	Axle Capacity	Gear Size
T69-170HP	T69-170HP	R69-170H	69,000 lbs.	17.7" Hypoid Gear
T78-190P	T78-190P	R78-190	78,000 lbs.	18.5" Hypoid Gear
T78-590P	T78-590P	R78-590	78,000 lbs.	18.5" Hypoid Gear

*Tridem model configuration consist of 3 axles; Two Forward Carriers and a Rear-Rear Carrier. Example would be: (D170>D170>R170) (D190>D190>R190) or (D590>D590>R590).

High Entry Single Axle Models

Single Axle	Axle Capacity	Gear Size
S21-170E	21,000 lbs.	17.7" Hypoid Gear
S23-170E	23,000 lbs.	17.7" Hypoid Gear
S25-170E	25,000 lbs.	17.7" Hypoid Gear
S23-190E	23,000 lbs.	18.5" Hypoid Gear
S26-190E	26,000 lbs.	18.5" Hypoid Gear
S30-190E	30,000 lbs.	18.5" Hypoid Gear

The suffix letter "P" in the model number indicates lube pump. The pump is designed to provide additional lubrication to the inter-axle differential and related parts. The "190" and "590" models come standard with pumps and the suffix letter "P" may not be referenced in all model callouts.

D170 / D190 Heavy Tandem Axle - Parts Exploded View

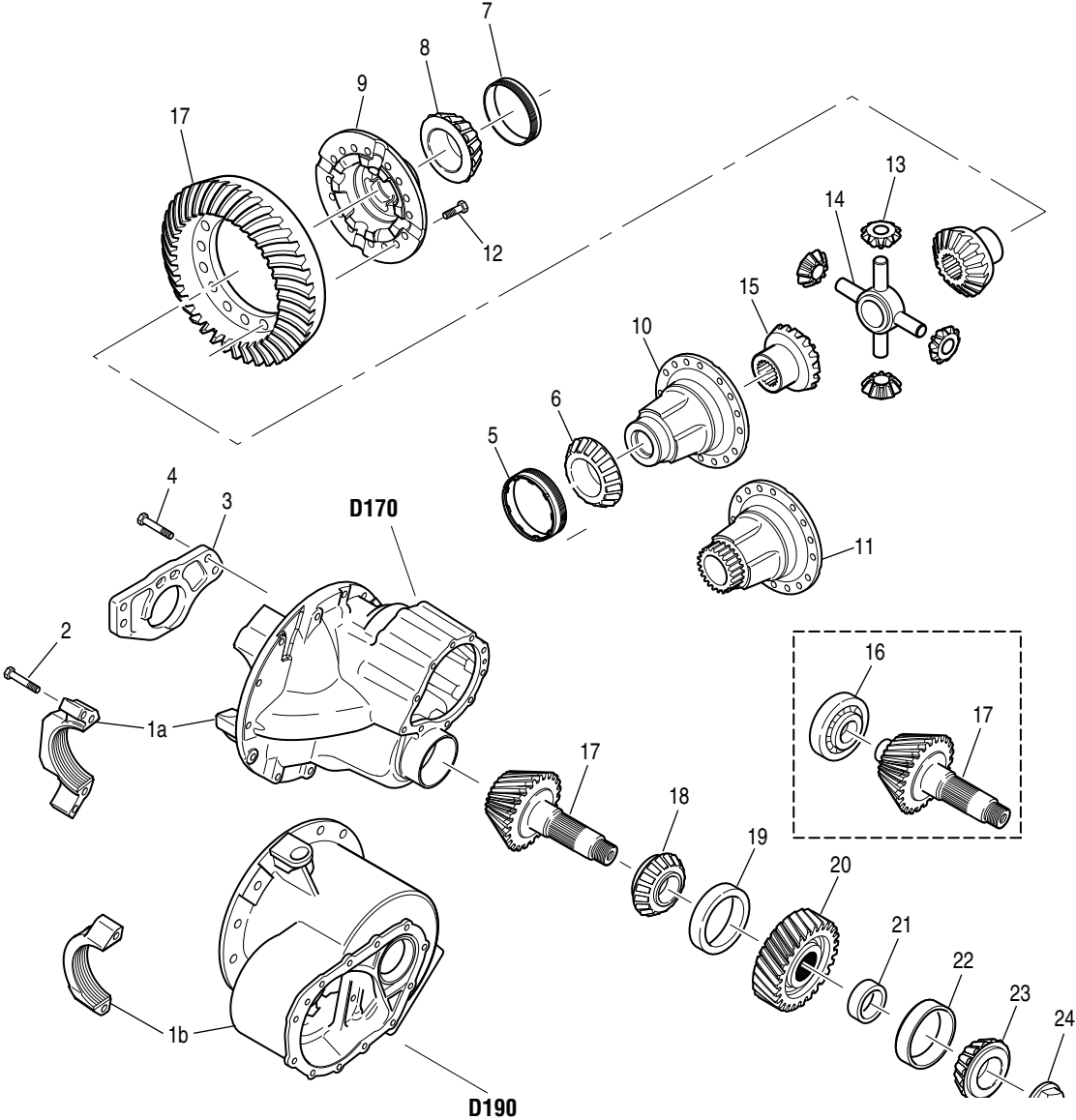

D170 / D190 Heavy Tandem Power Divider - Parts Exploded View

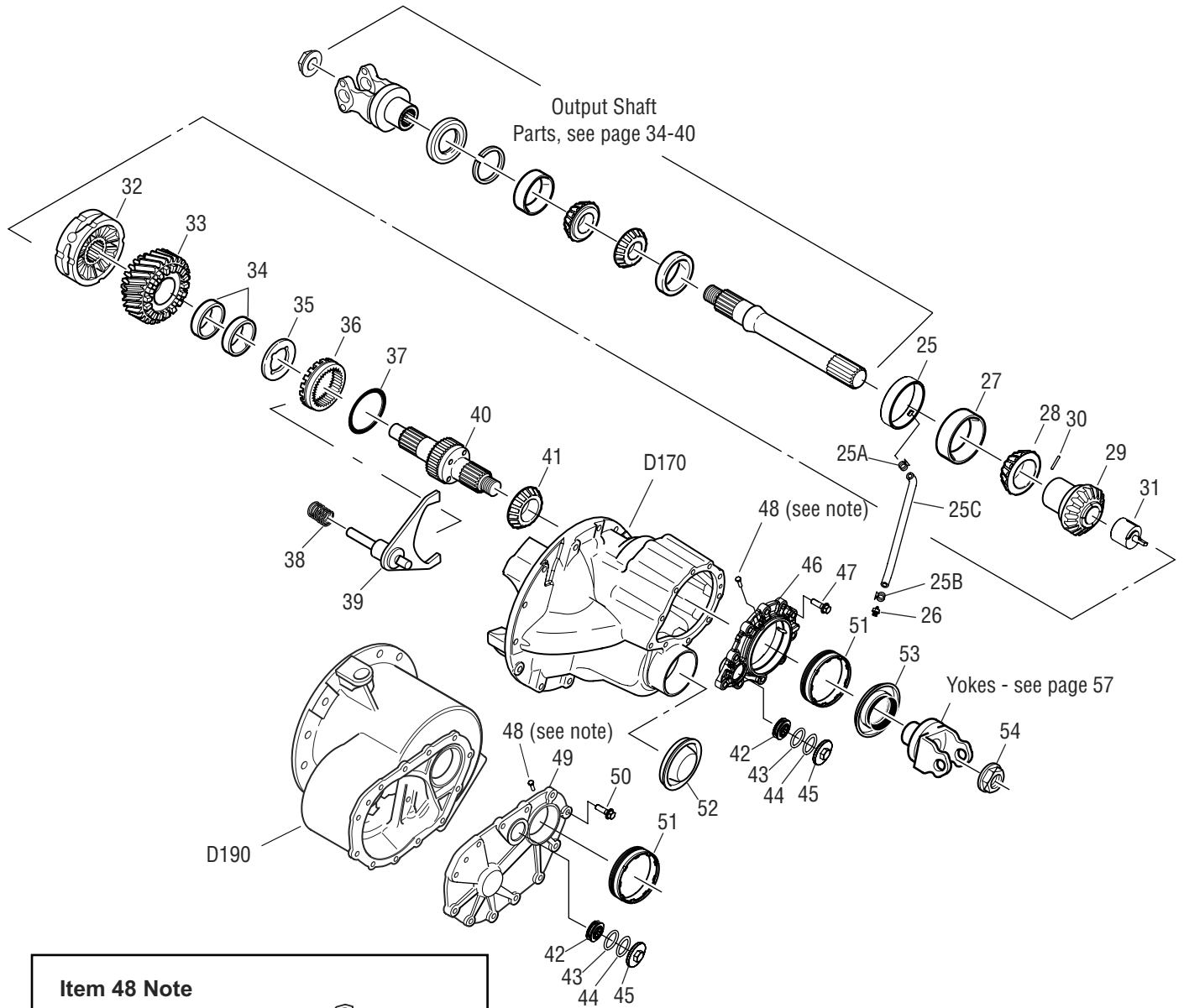

D170 / D190 Heavy Tandem Axle - Parts List

Item	Description	Qty Per Axle	D170 D170D	D190 D190D	Notes
	BEARING KIT	1	514238	514012	
	Contents identified with *	1	514011	-----	D170D Diff Lock Models Only
1a	Diff Carrier & Bearing Caps	1	513997	-----	D170 models
1a	Diff Carrier & Bearing Caps	1	513998	-----	D170D Diff Lock models - see chart pg 10
1b	Diff Carrier & Bearing Caps	1	-----	514001	All D190, D190D models - see chart pg 10
2	Capscrew - Bearing Cap	6	131016	131016	
3	Pilot Bearing Web Support	1	N/A	N/A	Not a serviceable part - order item 1
4	Capscrew - Pilot Bearing Web	4	N/A	131017	
5	Bearing Cup - Threaded Diff Plain Half	1	131044*	131048*	Standard models
		1	131048*	131048*	Diff Lock models
6	Bearing Cone - Diff Plain Half	1	131041*	131042*	Standard models
		1	131042*	131042*	Diff Lock models
7	Bearing Cup - Threaded Diff Flange Half	1	131044*	131044*	All models
8	Bearing Cone - Diff Flange Half	1	131041*	131041*	All models
9	Diff Case - Flange Half	1	See Kits Page 27-33		All models
10	Diff Case - Plain Half	1	See Kits Page 27-33		Standard models
11	Diff Case - Plain Half - Diff Lock	1	See Kits Page 27-33		Diff Lock models
	RING GEAR BOLT KIT	1	504069	504069	Includes qty 16 of 131473
12	Bolt - Ring Gear	16	131473	131473	
	WHEEL DIFF SIDE GEAR KIT		513868	513868	Includes items 13-15
13	Side Pinion	4	131040	131040	
14	Spider	1	131039	131039	
15	Side Gear - Differential	2	300GD101	300GD101	46 Inv Spline
	NO SPIN ASSEMBLY - 46 Inv	1	131882	-----	46 Inv Spline
16	Bearing - Pinion Pilot	1	129947*	129947*	
17	Ring Gear and Pinion - NSS	See Ring & Pinion Kits Page 55-56			
18	Bearing Cone - Inner Pinion	1	139968*	139968*	Replaces 131050 - Refer to bulletin HAXL-PNI-017
19	Bearing Cup - Inner Pinion	1	139969*	139969*	Replaces 131051 - Refer to bulletin HAXL-PNI-017
20	Pinion Helical Gear	1	131343	131343	
21	PINION BRG SPACER KIT	A/R	504041	504041	Individual pinion spacers listed on page 26
22	Bearing Cup - Outer Pinion	1	139972*	139972*	Replaces 131203 - Refer to bulletin HAXL-PNI-017
23	Bearing Cone - Outer Pinion	1	139971*	139971*	Replaces 131202 - Refer to bulletin HAXL-PNI-017
	PINION NUT KIT	1	131095K*	131095K*	Kit includes 24 & 55
24	Locknut - Pinion	1	131095	131095	Socket size 69mm
	MANIFOLD PARTS KIT				
	Pump Models	1	513878	513878	Includes items 25-26
	Non-Pump Model	1	513880	-----	Includes item 25
25	Manifold Assembly - NSS	1	131366-NSS	131366-NSS	Used in Pump models only
25a	Clamp	1	129338	129338	
25b	Collar Lock	1	134010	134010	
25c	Hose	1	131524	131524	
26	Screen Filter Assembly	1	133964	133964	Replaces 131370 & 131525
27	Bearing Cup - Output Side Gear	1	139976*	139976*	Replaces 131209 - Refer to bulletin HAXL-PNI-017
28	Bearing Cone - Output Side Gear	1	139975*	139975*	Replaces 131208 - Refer to bulletin HAXL-PNI-017

D170/ D190 Axle Parts List

Item	Description	Qty Per Axle	D170 D170D	D190 D190D	Notes
	LUBE PUMP KIT	1	504065	504065	Includes items 29-31 - replaces 513876 - Refer to bulletin HAXL-PNI-017
29	Output Side Gear - Non Pump	1	131467	-----	
	Output Side Gear - Pump	1	131466	131466	
30	Pin	1	131541	131541	Replaces 131369
31	Pump - Lube - NSS	1	131368-NSS	131368-NSS	Order Lube Pump Kit 504065
32	INTER-AXLE DIFFERENTIAL	1	139965	139965	Replaces 131339
33	Helical Side Gear & Bushing Assy.	1	131345	131345	Gear ID # 131005 includes item 34
34	Bushing - Helical Gear	2	131344	131344	
35	Thrust Washer	1	132440*	132440*	Replaces 131354
36	Sliding Clutch	1	131332	131332	
37	V-ring	1	131333*	131333*	
	SHIFT FORK & SPRING KIT	1	510870	514142	Includes items 38-39
38	Compression Spring	1	129859	129859	
39	Shift Fork Assembly - NSS	1	129856-NSS	131330-NSS	Must order kit above
	INPUT SHAFT KIT - NON-PUMP	1	513839	-----	Includes items 40a, 54-55
	INPUT SHAFT KIT - PUMP	1	513840	513840	Includes items 44b, 54-55
40a	Input Shaft - NSS - NON-PUMP	1	131348-NSS	-----	Order kit listed above
40b	Input Shaft - NSS - PUMP	1	131349-NSS	131349-NSS	Order kit listed above
41	Bearing Cone - Input Shaft	1	139973*	139973*	Replaces 131205 - Refer to bulletin HAXL-PNI-017
	AIR LOCKOUT REPAIR KIT	1	512892	512892	Includes items 42-45
	AIR LOCKOUT KIT (Complete w/Shift Fork)	1	512893	N/A	Includes items 38-39, 42-45
42	Piston	1	131232	131232	
43	O-Ring - Piston	1	210180	210180	
44	O-Ring Cover	1	131665	131665	Replaces 131496 & 220HH102
45	Piston Cover	1	131096	131096	
	INPUT COVER KIT - D170	1	504067	-----	Replaces 513881 & 514357, incl. 41, 46-48b, 50-51a
46	Input Cover - 131221-NSS	1	131686	-----	Order 504067 kit - Refer to bulletin HAXL-PNI-017
47	Capscrew - Input Cover	10	131374	-----	
48a	Nut - Adjuster Stud - M12 - current design	1	131693	131693	Refer to bulletin ABIB-0608
48b	Stud - Adjuster - M12 - current design	1	131692	131692	Refer to bulletin ABIB-0608
48c	Capscrew - Locking - M8 - early design	1	131373	131373	Refer to bulletin ABIB-0608
	INPUT COVER KIT - D190	1	-----	504066	Replaces 513879 & 514356, incl. 41, 48a-48b, 49-51a
49	Input Cover - 131328-NSS	1	-----	131687	Order 504066 kit - Refer to bulletin HAXL-PNI-017
50	Capscrew - Input Cover	12	-----	131374	
51	Input Adjuster & Cup Assy.	1	134354	134354	Replaces 131685 Refer to bulletin ABIB-0608 & HAXL-PNI-017
51a	Bearing Cup - Input Adjuster (not illustrated)	1	139974*	139974*	Replaces 131206 - part of item# 51 Refer to bulletin HAXL-PNI-017
52	Plug - Carier	1	131544	-----	Replaces 131224
	INPUT SEAL & LOCKNUT KIT	1	131008K	131008K	Includes items 53-55
53	Input Seal	1	134323*	134323*	Sold in 131008K kit also - replaces old seal# 131008
	INPUT NUT KIT	1	131095K	131095K	Includes item 54-55
54	Input Locknut	1	131095*	131095*	Socket size 69mm
55	Loctite	1	129293*	129293*	Not illustrated
56	RTV Sealant	1	107276S*	107276S*	Not illustrated

Note 1: Refer to Dana bulletin HAXL-PNI-017 for complete bearing change details

Note 2: Refer to Dana bulletin ABIB-0608 for complete Input Cover change details

Diff Carrier & Bearing Cap Kits

Item	Model	Kit Part No.	Notes
1a	D170	513997	Includes part 131223 and item 2
1a	D170D	513998	Includes part 131219 and item 2
1b	D190, D190D	514001	Includes part 131325 and items 2-4

Carrier/Cap Identification Information:

Part No.	Notes	Order No.
131223	No Pilot Web	order 513997
131219	No Pilot Web	order 513998
131325	Built w/Pilot Web	order 514001

To convert D170 Non-Pump Models to Pump Option, order:

1 - 513840 I/P Kit 1 - 504065 Lube Pump Kit 1 - 513878 Manifold Kit

D590 / D590D Double Reduction Axle - Parts Exploded View

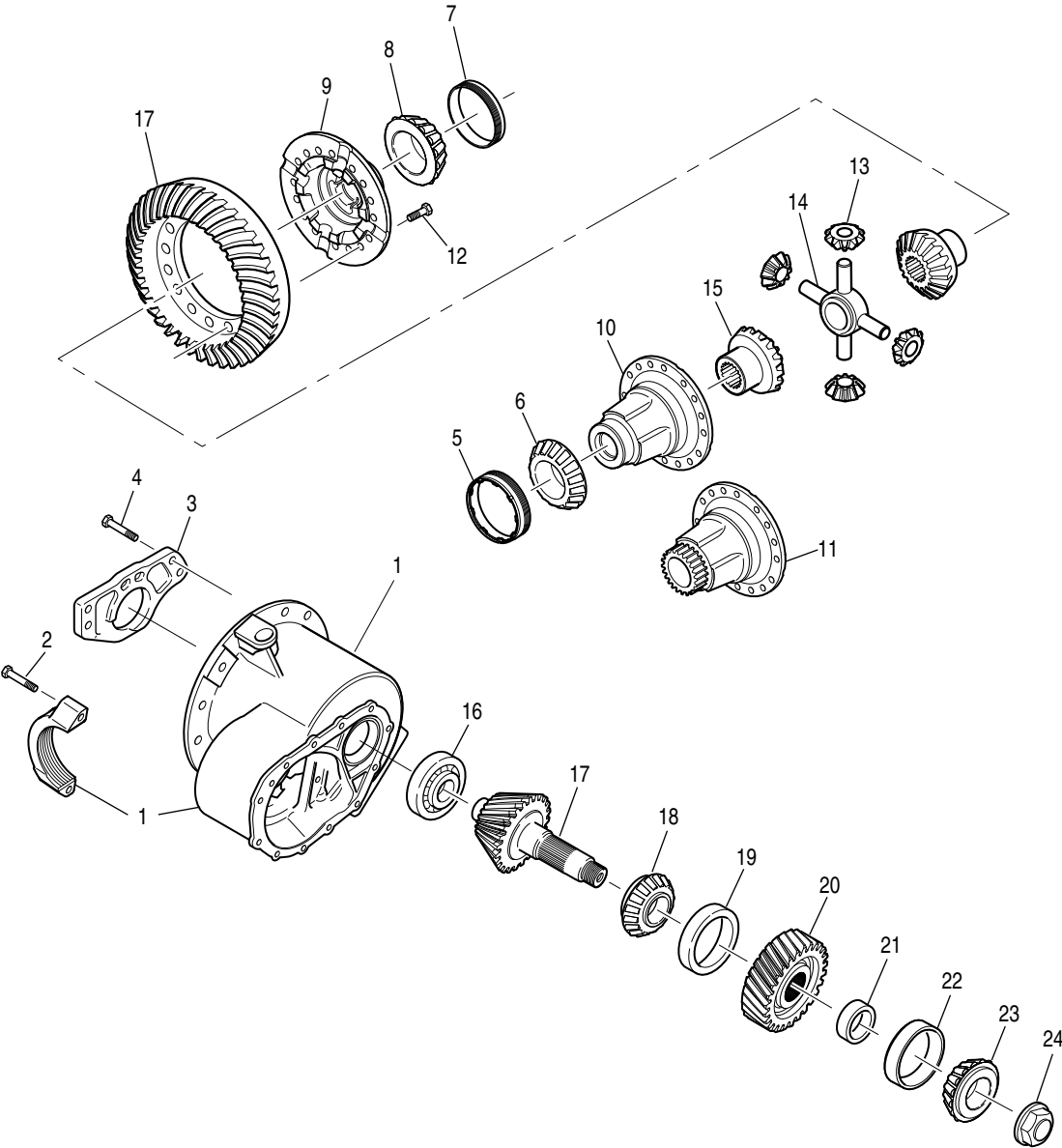

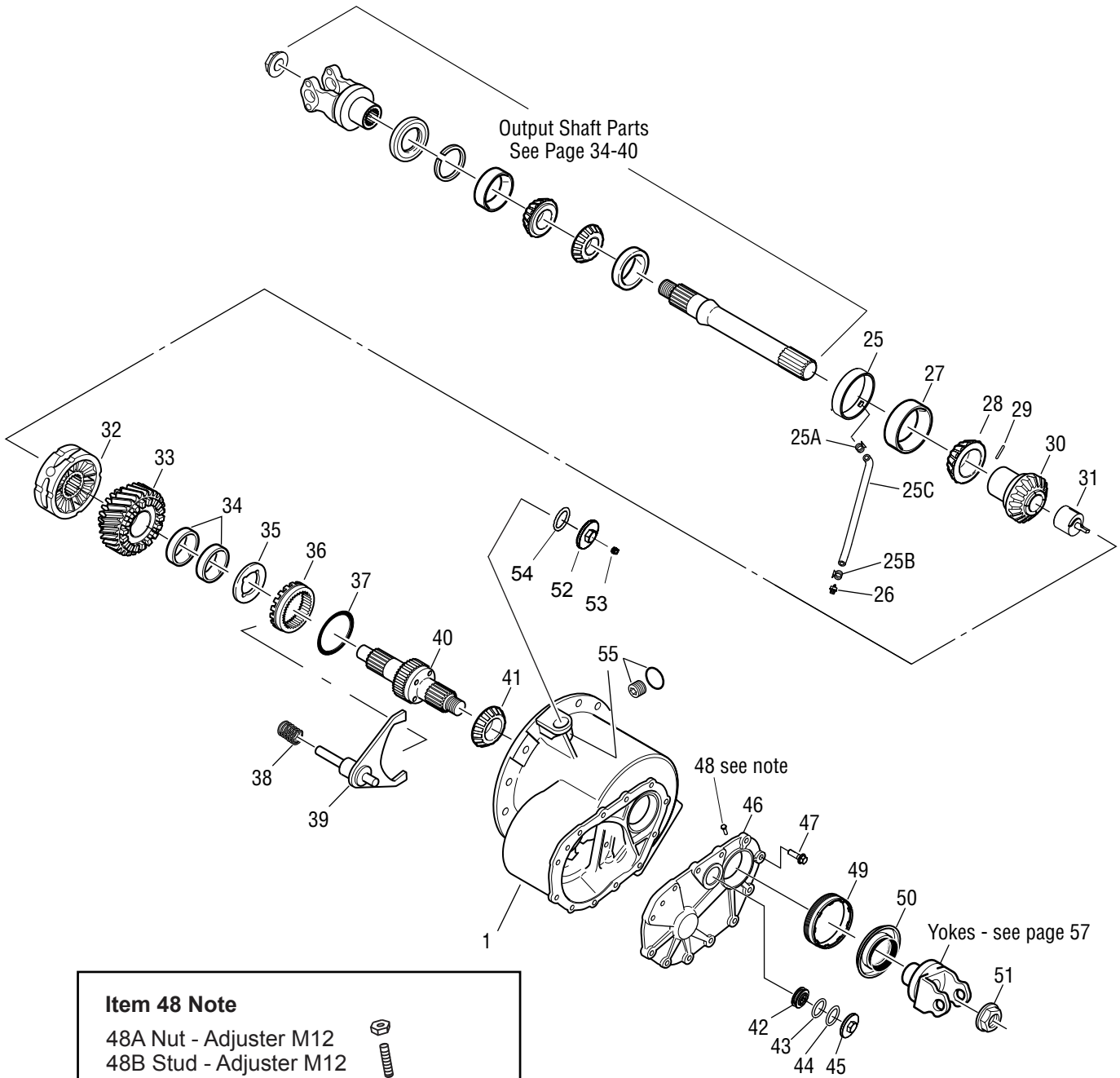

D590 / D590D Double Reduction Power Divider - Parts Exploded View



Item 48 Note

48A Nut - Adjuster M12 

48B Stud - Adjuster M12 

48C Capscrew (early models) M8 

D590 / D590D Double Reduction Axle - Parts List

Item	Description	Qty Per Axle	D590 D590D	Notes
BEARING KIT (contents identified with *)		1	504072	
1	Diff Carrier & Bearing Caps 131325-NSS	1	514001	Includes items 1-4
2	Capscrew - Bearing Cap	6	131016	
3	Pilot Bearing Web Support	1	N/A	Not a serviceable part - order item 1
4	Capscrew - Pilot Bearing Web	4	131017	
5	Bearing Cup - Threaded Diff Plain Half	1	131048*	
6	Bearing Cone - Diff Plain Half	1	131042*	
7	Bearing Cup - Threaded Diff Flange Half	1	131044*	
8	Bearing Cone - Diff Flange Half	1	131041*	
9	Diff Case - Flange Half	1	See Kits Page 27-29	All models
10	Diff Case - Plain Half	1	See Kits Page 27-29	Standard models
11	Diff Case - Plain Half - Diff Lock	1	See Kits Page 27-29	Diff Lock models
RING GEAR BOLT KIT		1	504069	Includes qty 16 of 131473
12	Bolt - Ring Gear	16	131473	
WHEEL DIFF SIDE GEAR KIT			513868	Includes items 13-15
13	Side Pinion	4	131040	
14	Spider	1	131039	
15	Side Gear - Differential	2	300GD101	46 Inv Spline
16	Bearing - Pinion Pilot	1	129947*	
17	Ring Gear and Pinion - NSS	See Ring & Pinion Kits Page 56		
18	Bearing Cone - Inner Pinion	1	139968*	Replaces 131050 - Refer to bulletin HAXL-PNI-017
19	Bearing Cup - Inner Pinion	1	139969*	Replaces 131051 - Refer to bulletin HAXL-PNI-017
20	Pinion Helical Gear 1.39:1	1	131249	1.39:1 Reduction
21 PINION BRG SPACER KIT		A/R	504041	Individual pinion spacers listed on page 26
22	Bearing Cup - Outer Pinion	1	139972*	Replaces 131203 - Refer to bulletin HAXL-PNI-017
23	Bearing Cone - Outer Pinion	1	139971*	Replaces 131202 - Refer to bulletin HAXL-PNI-017
PINION NUT KIT		1	131095K	Includes 24 & 56
24	Locknut - Pinion	1	131095	Socket size 69mm
MANIFOLD PARTS KIT		Pump Model	513878	Includes items 25-26
25	Manifold Assembly - NSS	1	131366-NSS	Pump models
25a	Clamp	1	129338	
25b	Collar Lock	1	134010	
25c	Hose	1	131524	
26	Screen Filter Assembly	1	133964	Replaces 131370 & 131525
27	Bearing Cup - Output Side Gear	1	139976*	Replaces 131209 - Refer to bulletin HAXL-PNI-017
28	Bearing Cone	1	139975*	Replaces 131208 - Refer to bulletin HAXL-PNI-017
LUBE PUMP KIT		1	504065	Includes items 29-31 - replaces 513876 - Refer to bulletin HAXL-PNI-017
29	Pin	1	131541	Included in kit was #131369
30	Output Side Gear	1	131466	Pump models
31	Pump - Lube - NSS	1	131368-NSS	Order Lube Pump Kit 504065

D590 / D590D Axle Parts List

Item	Description	Qty Per Axle	D590 D590D	Notes
32	INTER-AXLE DIFFERENTIAL	1	139965	Replaces 131339
33	Helical Side Gear & Bushing Assy. 1.39:1	1	131346	Gear stamp id# 131341, includes item 34
34	Bushing - Helical Gear	2	131344	
35	Thrust Washer	1	132440*	Replaces 131354
36	Sliding Clutch	1	131332	
37	V-ring	1	131333*	
SHIFT FORK & SPRING KIT		1	514142	Includes items 38-39
38	Compression Spring	1	129859	
39	Shift Fork Assembly - NSS	1	131330-NSS	Must order kit above
INPUT SHAFT KIT - PUMP		1	513840	Includes items 40, 51 & 56
40	Input Shaft - NSS - PUMP	1	131349-NSS	
41	Bearing Cone - Input Shaft	1	139973*	Replaces 131205 - Refer to bulletin HAXL-PNI-017
AIR LOCKOUT REPAIR KIT		1	512892	Includes items 42-45
42	Piston	1	131232	
43	O-Ring - Piston	1	210180	
44	O-Ring Cover	1	131665	Replaces 131496 & 220HH102
45	Piston Cover	1	131096	
INPUT COVER KIT		1	504066	Replaces 513879 & 514356, incl. items 41, 46-48b, 49-49a
46	Input Cover - 131328-NSS	1	131687	Order 504066 kit - Refer to bulletin HAXL-PNI-017
47	Capscrew - Input Cover	12	131374	
48a	Nut - Adjuster Stud - M12 - current design	1	131693	Refer to bulletin ABIB-0608
48b	Stud - Adjuster - M12 - current design	1	131692	Refer to bulletin ABIB-0608
48c	Capscrew - Locking - M8 - early design	1	131373	Refer to bulletin ABIB-0608
49	Input Adjuster & Cup Assy.	1	134354	Replaces 131685 - Refer to bulletin ABIB-0608 & HAXL-PNI-017
49a	Brg Cup - Input Adjuster (not illustrated)	1	139974*	Replaces 131206 - part of item# 49 - Refer to bulletin HAXL-PNI-017
INPUT SEAL & LOCKNUT KIT		1	131008K	Includes items 50-51 & 56
50	Input Seal	1	134323*	Sold in 131008K kit also - replaces old seal# 131008
INPUT NUT KIT		1	131095K	Includes item 51 & 56
51	Input Locknut	1	131095	Socket size 69mm
52	Cover - Diff Lock Shift	1	131096	For Non-Diff Lock mdl's - for diff lock models see page 30
53	Plug - Diff Lock Shift	1	127195	For Non-Diff Lock mdl's - for diff lock models see page 30
54	O-Ring - Diff Lock Cover	1	131665	For Non-Diff Lock mdl's - for diff lock models see page 30
55	Plug & O-Ring - Diff Lock Cylinder	1	131487	For Non-Diff Lock mdl's - for diff lock models see page 30
56	Loctite	1	129293	Not illustrated
57	RTV Sealant	1	107276S*	Not illustrated

Note 1: Refer to Dana bulletin HAXL-PNI-017 for complete bearing change details

Note 2: Refer to Dana bulletin ABIB-0608 for complete Input Cover change details

Diff Carrier & Bearing Cap Kits

Item	Model	Kit Part No.	Notes
1	D590, D590D	514001	Includes items 1, 2-4

Carrier/Cap Identification Information:

Part No.	Notes
131325	Built w/Pilot Web order 514001

S590 / S590D / R590 / R590D Double Reduction Axle - Parts Exploded View

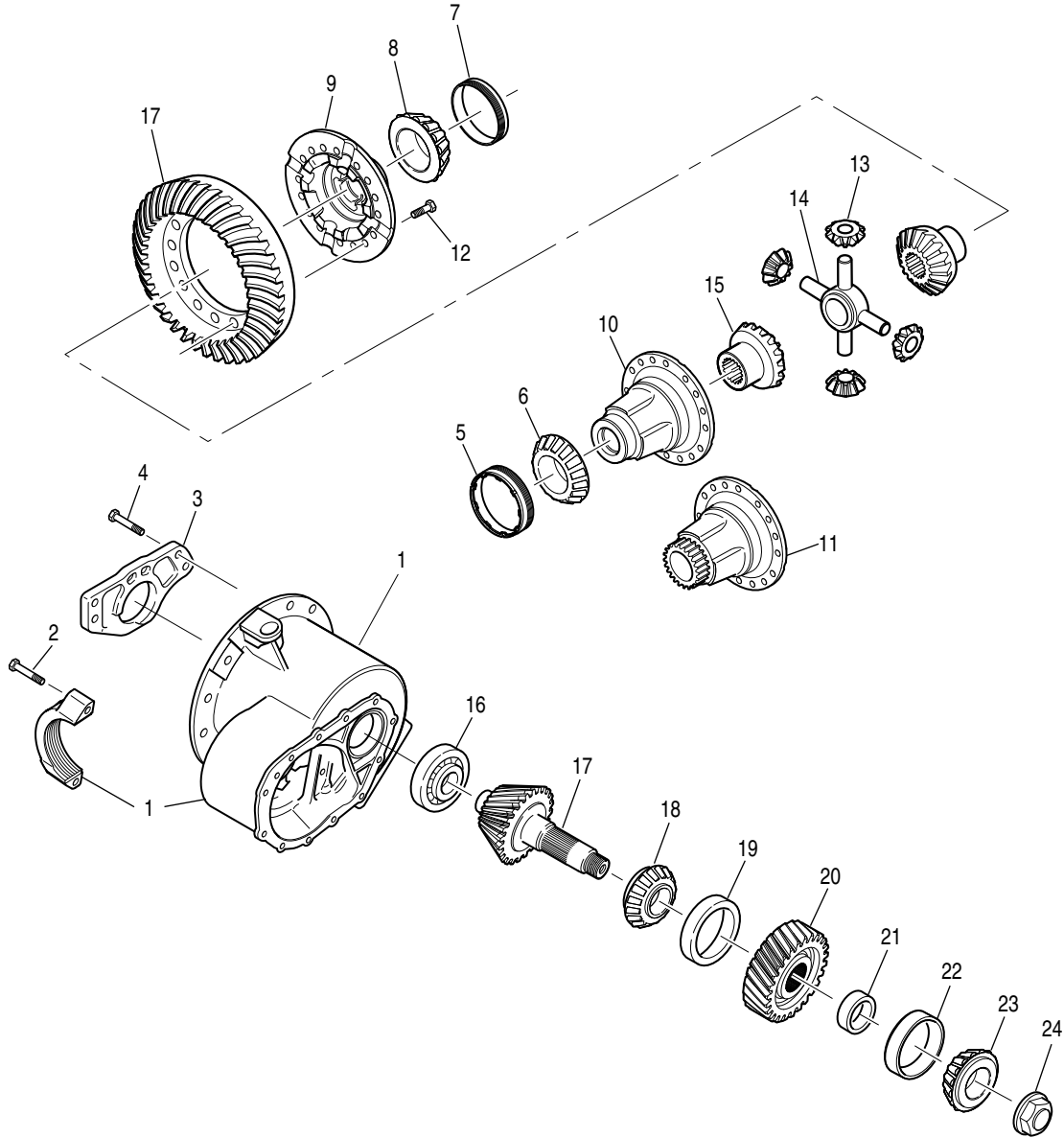

S590 / S590D / R590 / R590D Double Reduction Power Divider - Parts Exploded View

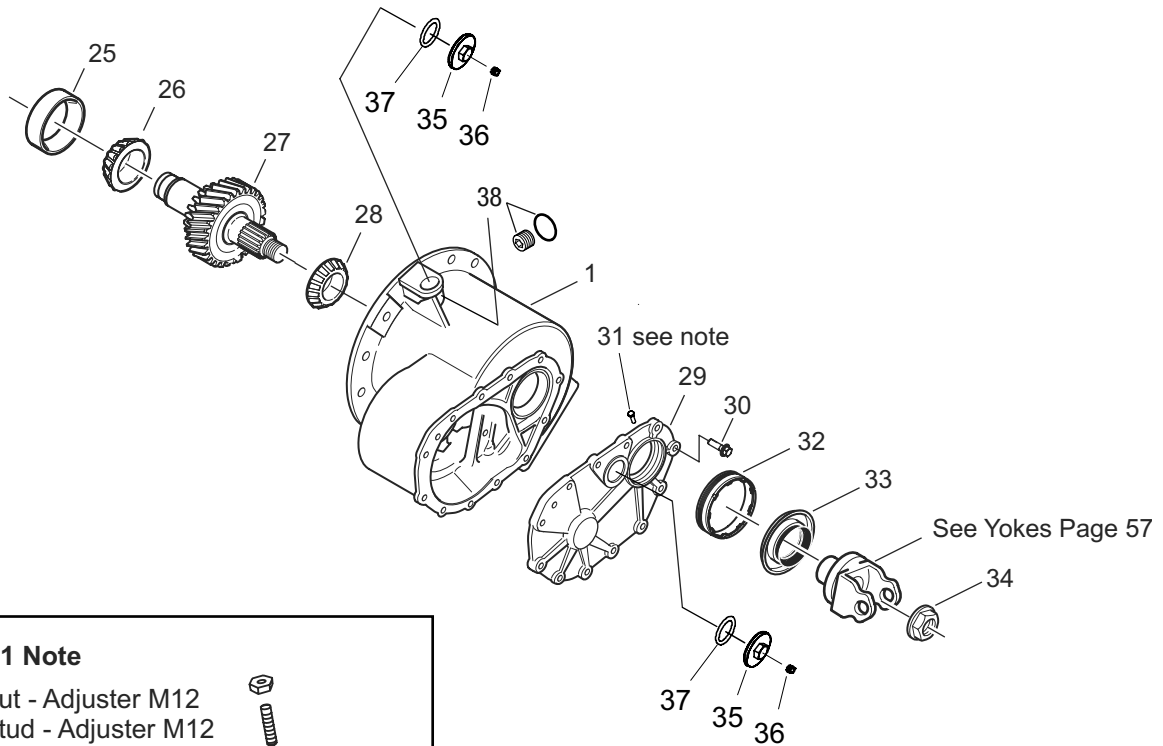

Item 31 Note

31A Nut - Adjuster M12
 31B Stud - Adjuster M12



31C Capscrew (early models) M8



S590 / S590D / R590 / R590D Double Reduction Axle - Parts List

Item	Description	Qty Per Axle	S590, S590D, R590 R590D	Notes
BEARING KIT (contents identified with *)		1	504073	
1	Diff Carrier & Bearing Caps - 131325-NSS	1	514001	Includes items 1-4
2	Capscrew - Bearing Cap	6	131016	
3	Pilot Bearing Web Support	1	N/A	Not a serviceable part - order item 1
4	Capscrew - Pilot Bearing Web	4	131017	
5	Bearing Cup - Threaded Diff Plain Half	1	131048*	
6	Bearing Cone - Diff Plain Half	1	131042*	
7	Bearing Cup - Threaded Diff Flange Half	1	131044*	
8	Bearing Cone - Diff Flange Half	1	131041*	
9	Diff Case - Flange Half	1	See Kits Page 27-33	All models
10	Diff Case - Plain Half	1	See Kits Page 27-33	Standard models
11	Diff Case - Plain Half - Diff Lock	1	See Kits Page 27-33	Diff Lock models
RING GEAR BOLT KIT		1	504069	Includes qty 16 of 131473
12	Bolt - Ring Gear	16	131473	
WHEEL DIFF SIDE GEAR KIT			513868	Includes items 13-15
13	Side Pinion	4	131040	
14	Spider	1	131039	
15	Side Gear - Differential	2	300GD101	46 Inv Spline
16	Bearing - Pinion Pilot	1	129947*	
17	Ring Gear and Pinion - NSS	See Ring & Pinion Kits Page 56		
18	Bearing Cone - Inner Pinion	1	139968*	Replaces 131050 - Refer to bulletin HAXL-PNI-017
19	Bearing Cup - Inner Pinion	1	139969*	Replaces 131051 - Refer to bulletin HAXL-PNI-017
20	Pinion Helical Gear 1.39:1	1	131249	1.39:1 Reduction
21	PINION BRG SPACER KIT	A/R	504041	Individual pinion spacers listed on page 26
22	Bearing Cup - Outer Pinion	1	139972*	Replaces 131203 - Refer to bulletin HAXL-PNI-017
23	Bearing Cone - Outer Pinion	1	139971*	Replaces 131202 - Refer to bulletin HAXL-PNI-017
PINION NUT KIT		1	131095K	Kit includes 24 & 39 loctite
24	Locknut - Pinion	1	131095	Socket size 69mm
25	Bearing Cup	1	139976*	Replaces 131209 - Refer to bulletin HAXL-PNI-017
26	Bearing Cone	1	139975*	Replaces 131208 - Refer to bulletin HAXL-PNI-017
27	Input Shaft & Helical Gear 1.39:1		131353	
28	Bearing Cone - Input Shaft	1	139973*	Replaces 131205 - Refer to bulletin HAXL-PNI-017
INPUT COVER KIT		1	504066	Replaces 513879 & 514356, incl. items 28, 29-31b, 32-32a
29	Input Cover - 131328-NSS	1	131687	Order 504066 kit - Refer to bulletin HAXL-PNI-017
30	Capscrew - Input Cover	12	131374	
31a	Nut - Adjuster Stud - M12 - current design	1	131693	Refer to bulletin ABIB-0608
31b	Stud - Adjuster - M12 - current design	1	131692	Refer to bulletin ABIB-0608
31c	Capscrew - Locking - M8 - early design	1	131373	Refer to bulletin ABIB-0608
32	Input Adjuster & Cup Assy.	1	134354	Replaces 131685 - Refer to bulletin ABIB-0608 & HAXL-PNI-017
32a	Bearing Cup - Input Adjuster (not illustrated)	1	139974*	Replaces 131206 - part of item# 32 - Refer to bulletin HAXL-PNI-017

S590 / S590D / R590 Axle Parts List

Item	Description	Qty Per Axle	S590, S590D,	R590 R590D	Notes
INPUT SEAL & LOCKNUT KIT		1	131008K		Includes items 33-34, 39
33	Input Seal	1	134323*		Sold in 131008K kit also - replaces old seal# 131008
INPUT NUT KIT		1	131095K		Includes item 34 & 39
34	Input Locknut	1	131095		Socket size 69mm
35	Cover - Diff Lock Shift	2	131096		See Note 3
36	Plug - Diff Lock Shift	2	127195		See Note 3
37	O-Ring - Diff Lock Cover	2	131665		See Note 3
38	Plug & O-Ring - Diff Lock Cover	1	131487		For Non-Diff Lock models only
39	Loctite adhesive	1	129293		Not illustrated
40	RTV Sealant	1	107276S*		Not illustrated

Note 1: Refer to Dana bulletin HAXL-PNI-017 for complete bearing change details

Note 2: Refer to Dana bulletin ABIB-0608 for complete Input Cover change details

Note 3: Quantity use is 2 unless you have a Diff Lock model, see page 30 for diff lock shift parts

Diff Carrier & Bearing Cap Kits

Item	Model	Kit Part No.	Notes
1	S590, S590D, R590, R590D	514001	Includes items 1-4

Carrier/Cap Identification Information:

Part No.	Notes
131325	Built w/Pilot Web order 514001

S170E / S190E / S190DE High Entry Axle - Parts Exploded View

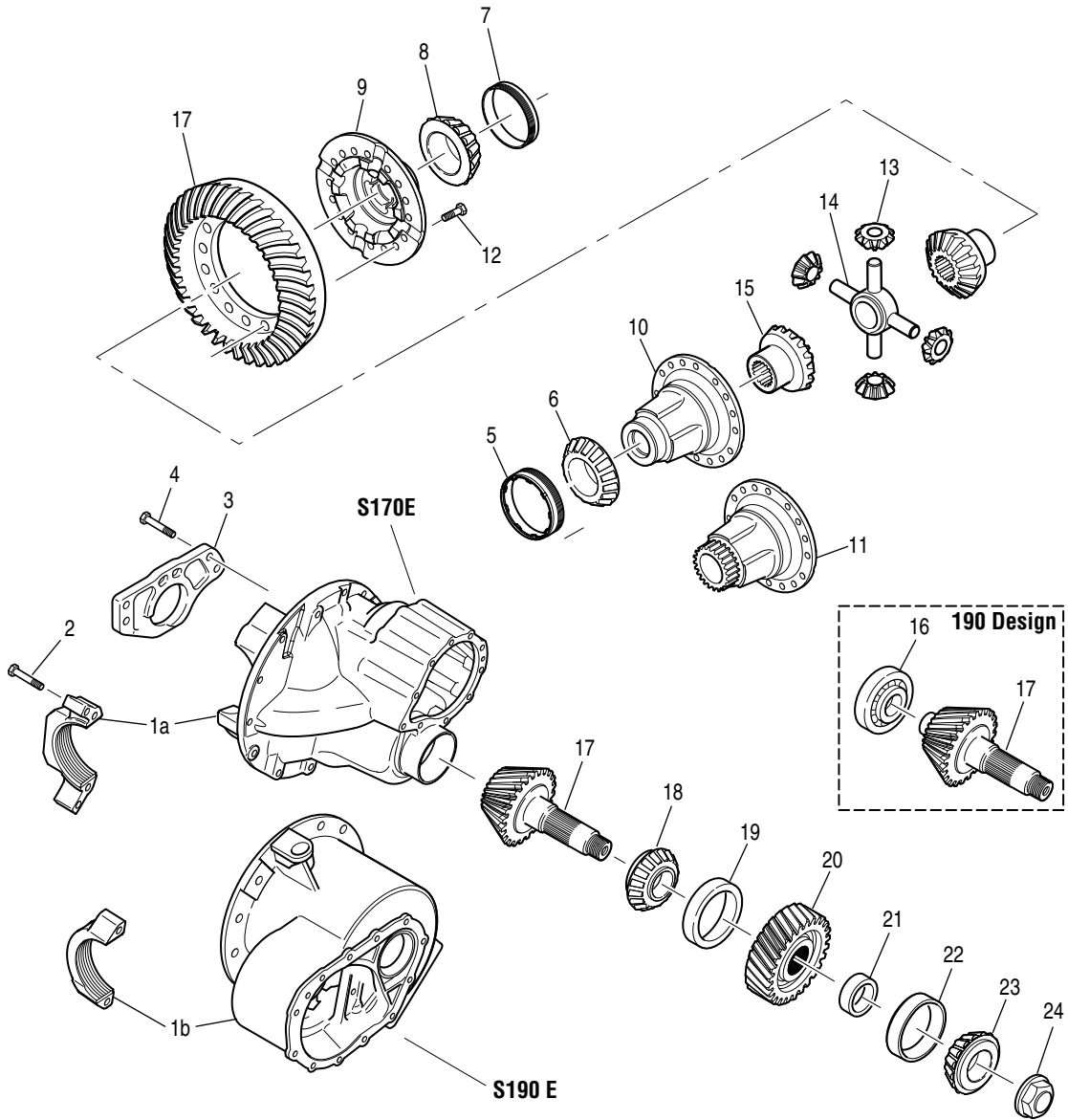

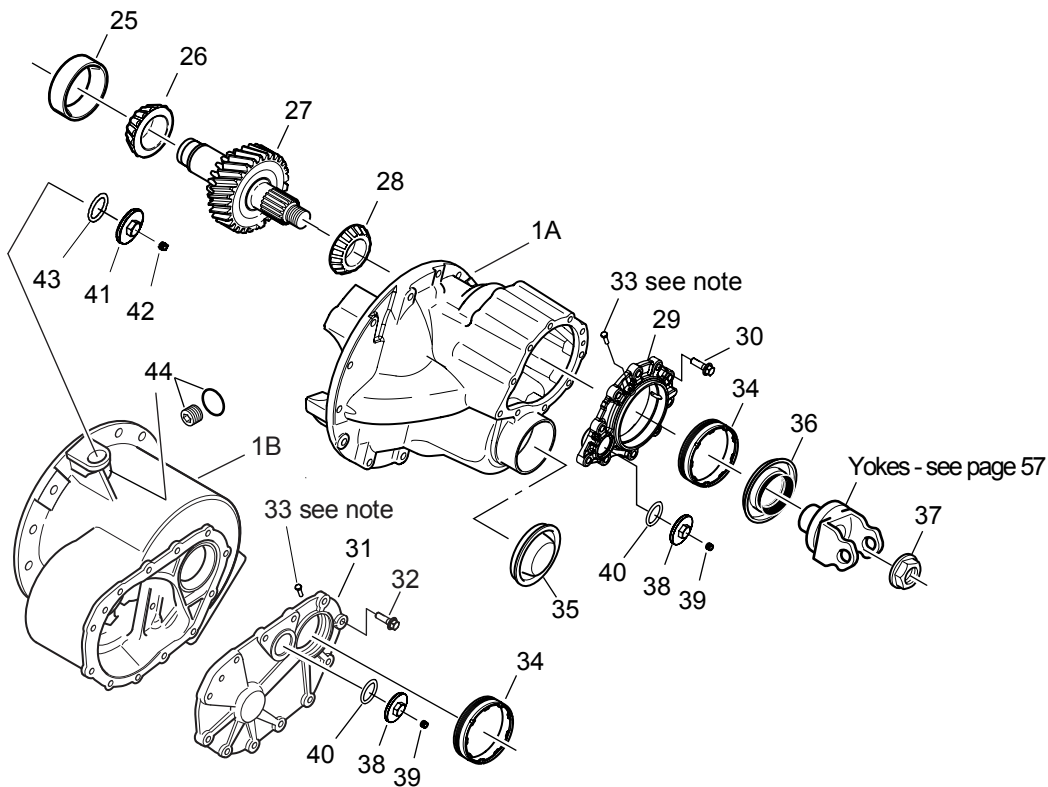

Parts for
Diff Lock Assembly
See page 30

S170E / S190E / S190DE High Entry Power Divider - Parts Exploded View



Item 33 Note

33A Nut - Adjuster M12 

33B Stud - Adjuster M12 

33C Capscrew (early models) M8 

S170E / S190E / S190DE High Entry Axle - Parts List

Item	Description	Qty Per Axle	S170E	S190E	S190DE	Notes
BEARING KIT		1	504074	504073	504073	Contents identified with *
1a	Diff Carrier & Bearing Caps - 131223-NSS	1	513997	-----	-----	Includes items 1a & 2
1b	Diff Carrier & Bearing Caps - 131325-NSS	1	-----	514001	514001	Includes items 1b-4
2	Capscrew - Bearing Cap	6	131016	131016	131016	
3	Pilot Bearing Web Support	1	-----	N/A	N/A	Not a serviceable part - order item 1
4	Capscrew - Pilot Bearing Web	4	-----	131017	131017	
5	Bearing Cup - Threaded Diff Plain Half	1	131044*	131048*	131048*	
6	Bearing Cone - Diff Plain Half	1	131041*	131042*	131042*	
7	Bearing Cup - Threaded Diff Flange Half	1	131044*	131044*	131044*	
8	Bearing Cone - Diff Flange Half	1	131041*	131041*	131041*	
9	Diff Case - Flange Half	1	See Kits Page 27-33			All models
10	Diff Case - Plain Half	1	See Kits Page 27-33			Standard models
11	Diff Case - Plain Half - Diff Lock	1	See Kits Page 27-33			Diff Lock models
RING GEAR BOLT KIT		1	504069	504069	504069	Includes qty 16 of 131473
12	Bolt - Ring Gear	16	131473	131473	131473	
WHEEL DIFF SIDE GEAR KIT			513868	513868	513868	Includes items 13-15
13	Side Pinion	4	131040	131040	131040	
14	Spider	1	131039	131039	131039	
15	Side Gear - Differential	2	300GD101	300GD101	300GD101	46 Inv Spline
NO SPIN ASSEMBLY - 46 Inv		1	131882	-----	-----	46 Inv Spline (not illustrated)
16	Bearing - Pinion Pilot	1	-----	129947*	129947*	
17	Ring Gear and Pinion - NSS		See Ring & Pinion Kits Page 55-56			
18	Bearing Cone - Inner Pinion	1	139968*	139968*	139968*	Replaces 131050 - See Note 1
19	Bearing Cup - Inner Pinion	1	139969*	139969*	139969*	Replaces 131051 - See Note 1
20	Pinion Helical Gear	1	131343	131343	131343	
21 PINION BRG SPACER KIT		A/R	504041	504041	504041	Individual pinion spacers listed on pg 26
22	Bearing Cup - Outer Pinion	1	139972*	139972*	139972*	Replaces 131203 - See Note 1
23	Bearing Cone - Outer Pinion	1	139971*	139971*	139971*	Replaces 131202 - See Note 1
PINION NUT KIT		1	131095K	131095K	131095K	Includes 24 & 45
24	Locknut - Pinion	1	131095	131095	131095	Socket size 69mm
25	Bearing Cup - Output Side Gear	1	139976*	139976*	139976*	Replaces 131209 - See Note 1
26	Bearing Cone - Output Side Gear	1	139975*	139975*	139975*	Replaces 131208 - See Note 1

Note 1: Refer to Dana bulletin HAXL-PNI-017 for complete bearing change details

S170E/S190E/S190DE Parts List

Item	Description	Qty Per Axle	S170E	S190E	S190DE	Notes
27	INPUT SHAFT & HELICAL - HIGH ENTRY	1	131340	131340	131340	1:1 ratio
28	Bearing Cone - Input Shaft	1	139973*	139973*	139973*	Replaces 131205 - See Note 1
	INPUT COVER KIT - S170E	1	504067	-----	-----	Replaces 513881 & 514357 Includes 26, 29-30, 33a-b, 34-34a
29	Input Cover - 131221-NSS	1	131686	-----	-----	Order 504067 kit - See Note 1
30	Capscrew - Input Cover	10	131374	-----	-----	
	INPUT COVER KIT - S190E/S190DE	1	-----	504066	504066	Replaces 513879 & 514356 Includes items 26, 31-33b, 34-34a
31	Input Cover - 131328-NSS	1	-----	131687	131687	Order 504066 kit - See Note 1
32	Capscrew - Input Cover	12	-----	131374	131374	
33a	Nut - Adjuster Stud - M12 - current design	1	131693	131693	131693	See Note 2
33b	Stud - Adjuster - M12 - current design	1	131692	131692	131692	See Note 2
33c	Capscrew - Locking - M8 - early design	1	131373	131373	131373	See Note 2
34	Input Adjuster & Cup Assy.	1	134354	134354	134354	Replaces 131685 - See Notes 1 & 2
34a	Bearing Cup - Input Adjuster (not illustrated)	1	139974*	139974*	139974*	Replaces 131206 - part of item# 34 See Note 1
35	Plug - Carrier	1	131544	-----	-----	Replaces 131224
	INPUT SEAL & LOCKNUT KIT	1	131008K	131008K	131008K	Includes items 36-37 & 45
36	Input Seal	1	134323*	134323*	134323*	Replaces 131008
	INPUT NUT KIT	1	131095K	131095K	131095K	Includes item 37 & 45
37	Input Locknut	1	131095	131095	131095	Socket size 69mm
38	Cap - Lockout Cylinder	1	131096	131096	131096	
39	Plug - Cap - Lockout Cylinder	1	127195	127195	127195	
40	O-Ring - Cap - Lockout Cylinder	1	131665	131665	131665	
41	Cap - Diff Lock Shift Cylinder	1	131096	131096	-----	Non-Diff Lock mdls-for diff lockout see pg 30
42	Plug - Cap - Diff Lock Shift Cylinder	1	127195	127195	-----	Non-Diff Lock mdls-for diff lockout see pg 30
43	O-Ring - Cap - Diff Lock Shift Cylinder	1	131665	131665	-----	Non-Diff Lock mdls-for diff lockout see pg 30
44	Plug & O-Ring - Diff Lock Switch Opening	1	131487	131487	-----	Non-Diff Lock mdls-for diff lockout see pg 30
45	Loctite	1	129293	129293	129293	Not illustrated
46	RTV Sealant	1	107276S*	107276S*	107276S*	Not illustrated

Note 1: Refer to Dana bulletin HAXL-PNI-017 for complete bearing change details

Note 2: Refer to Dana bulletin ABIB-0608 for complete Input Cover change details

Diff Carrier & Bearing Cap Kits

Item	Model	Kit Part No.	Notes
1a	S170E	513997	Includes part 131223 and item 2
1b	S190E, S190DE	514001	Includes part 131325 and items 2-4

Carrier/Cap Identification Information:

Part No.	Notes
131223	No Pilot Web order 513997
131325	Built w/Pilot Web order 514001

R170 / R190, S170 / S190 Heavy Tandem Axle - Parts Explode

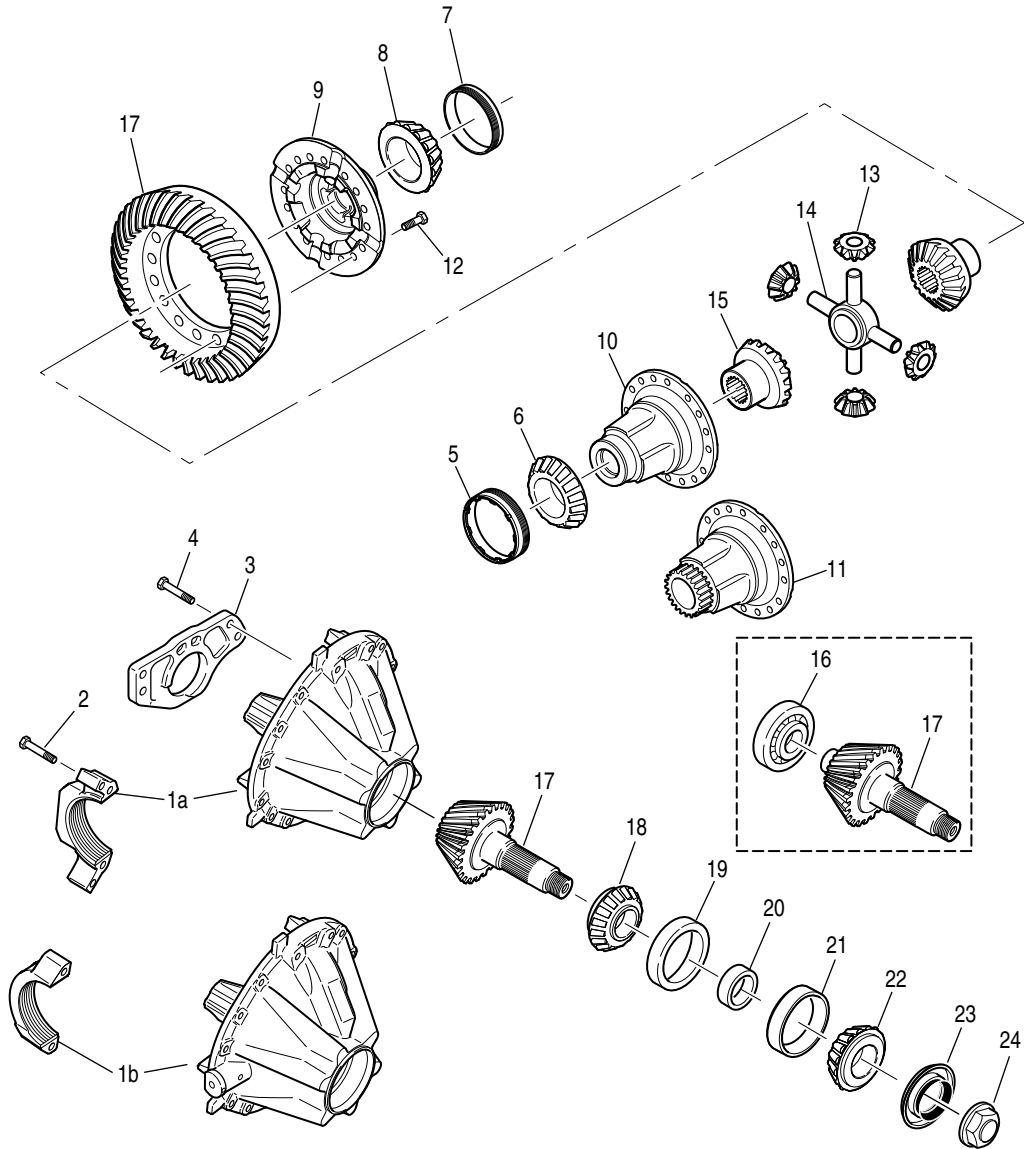

R170 / R190, S170 / S190 Heavy Tandem Axle - Parts List

Item	Description	Qty Per Axle	S170 S170D R170 R170D	S190 S190D R190 R190D	Notes
BEARING KIT		1	-----	514015	190 Series - ratios 2.53-4.78
Contents Identified with *		1	-----	514016	190 Series - ratios 5.25-7.83
		1	514013	-----	S170S Series - ratios 2.69-3.91
		1	514014	-----	S170S Series - ratios 4.10-7.17
		1	514239	-----	S170D - Diff Lock Series - ratios 2.69-3.91
		1	514240	-----	S170D - Diff Lock Series - ratios 4.10-7.17
1a	Diff Carrier & Bearing Caps	1	513999	-----	R170, S170 models - see content below
1b	Diff Carrier & Bearing Caps	1	514000	-----	R170D, S170D diff lock mdl's - see content below
1c	Diff Carrier & Bearing Caps	1	-----	514002	All R190, S190, R190D, S190D - see content below
2	Capscrew - Bearing Cap	6	131016	131016	
3	Pilot Bearing Web Support	1	NSS - Note 3	NSS	Not a serviceable part - see Note 3 next page
4	Capscrew - Pilot Bearing Web	4	131017- Note 3	131017	See note 3 next page
5	Bearing Cup - Threaded Diff Plain Half	1	131044*	131048*	Standard Model
		1	131048*	131048*	Diff Lock Model
6	Diff Bearing Cone - Flange Half	1	131041*	131042*	Standard Model
		1	131042*	131042*	Diff Lock Model
7	Bearing Cup - Threaded Diff Flange Half	1	131044*	131044*	All Models
8	Bearing Cone - Diff Flange Half	1	131041*	131041*	All Models
9	Diff Case - Flange Half	1	See Kits Page 27-33		All models
10	Diff Case - Plain Half	1	See Kits Page 27-33		Standard models
11	Diff Case - Plain Half - Diff Lock	1	See Kits Page 27-33		Diff Lock models
RING GEAR BOLT KIT		1	504069	504069	Includes qty 16 of 131473
12	Ring Gear Bolt	16	131473	131473	
WHEEL DIFF SIDE GEAR KIT			513868	513868	Includes items 13-15
13	Side Pinion	4	131040	131040	
14	Spider	1	131039	131039	
15	Side Gear - Differential	2	300GD101	300GD101	46 Involute
NO SPIN ASSEMBLY - 46 Inv		1	131882	-----	46 Inv Spline
16	Bearing - Pinion Pilot	Ratios 2.69 - 3.91	1	129947*	N/A
		Ratios 2.53 - 4.78	1	-----	129947*
		Ratios 5.25 - 7.83	1	-----	126187*
17	Ring Gear & Drive Pinion Set	See Ring & Pinion Kits Page 55-56			
18	Bearing Cone - Inner Pinion	1	139968*	139968*	Replaces 131050 - Refer to bulletin HAXL-PNI-017
19	Bearing Cup - Inner Pinion	1	139969*	139969*	Replaces 131051 - Refer to bulletin HAXL-PNI-017
20	PINION BRG SPACER KIT	A/R	504042	504042	Individual pinion spacers listed on page 26
21	Bearing Cup - Outer Pinion	1	139969*	139969*	Replaces 131051 - Refer to bulletin HAXL-PNI-017
22	Bearing Cone - Outer Pinion	1	139970*	139970*	Replaces 131052 - Refer to bulletin HAXL-PNI-017
INPUT SEAL & LOCKNUT KIT		1	131008K	131008K	Includes items 23-25
23	Input Seal	1	134323*	134323*	Also sold in 131008K kit also -replaces seal# 131008
INPUT NUT KIT		1	131095K	131095K	Includes item 24-25
24	Locknut - Pinion	1	131095*	131095*	Socket size 69mm
25	Loctite	1	129293*	129293*	Not illustrated
26	RTV Sealant	1	107276S*	107276S*	Not illustrated

* Note 1: Refer to Dana bulletin HAXL-PNI-017 for complete bearing change details

* Note 2: Refer to Dana bulletin ABIB-0608 for complete Input Cover change details

Diff Carrier & Bearing Cap Kits

Note 3: Some 170 Series models utilize the Pilot Web, while others are the overhung design (no Pilot Web). All service replacement carrier/cap kits include the Pilot Web design.

Item	Model	Kit Part No.	Notes
1a	R170, S170	513999	Includes part 131019 and items 2-4
1b	R170D, S170D	514000	Includes part 131021 and items 2-4
1c	R190, S190D, R190D, S190D	514002	Includes part 131025 and items 2-4

Carrier/Cap Identification Information

Part No.	Notes
131019-NSS	Built w/Pilot Web order 513999
131021-NSS	Built w/Pilot Web order 514000
131025-NSS	Built w/Pilot Web order 514002
131229-NSS	No Pilot Web order 513999
131231-NSS	No Pilot Web order 514000

Bearing Spacers

Select a variable pinion bearing spacer from the list below to attain the correct pinion bearing preload. All procedures on "Pinion Bearing Preload" remain the same and the proper steps should be followed according to your Dana Spicer Service Manual AXSM0057. Spicer Pinion Bearing Spacer kits are available as shown below.

PINION BRG SPACER KIT: 504041

Models: ALL D170, D190, D/R590, S590, D170E/D190E

Dana P/N	Spacer Thickness (mm)	Dana P/N	Spacer Thickness (mm)
131376	21.760	131392	22.120
*131408	22.360	132838	21.775
131377	21.790	*131393	22.135
*131409	22.375	132839	21.805
*131378	21.820	131394	22.150
131410	22.390	132840	21.835
131379	21.850	131395	22.165
131411	22.405	132841	21.865
131380	21.880	131396	22.180
131412	22.420	132842	21.895
131381	21.910	131397	22.195
*131413	22.435	132843	21.925
131382	21.940	131398	22.210
131414	22.450	*132844	21.955
131383	21.970	*131399	22.225
131415	22.465	132845	21.985
131384	22.000	*131400	22.240
131416	22.495	132846	22.470
131385	22.015	131401	22.255
131417	22.525	132847	22.510
131386	22.030	131402	22.270
131418	22.555	132848	22.540
131387	22.045	131403	22.285
131419	22.585	132849	22.570
131388	22.060	131404	22.300
131420	22.615	132850	22.600
131389	22.075	131405	22.315
*131421	22.645	132851	22.630
131390	22.090	131406	22.330
131422	22.675	132852	22.660
*131391	22.105	131407	22.345
131423	22.705	132853	22.680

PINION BRG SPACER KIT: 504042

Models: ALL R170, S170, R190, S190

Dana P/N	Spacer Thickness (mm)	Dana P/N	Spacer Thickness (mm)
131053	7.750	131061	7.945
131074	8.140	132832	8.335
132825	7.765	131062	7.960
131075	8.155	131085	8.350
131054	7.780	131063	7.975
131076	8.170	132833	8.365
132826	7.795	131064	7.990
*131077	8.185	*132834	8.395
131055	7.810	*131065	8.005
131078	8.200	131086	8.380
132827	7.825	131066	8.020
*131079	8.215	131087	8.410
131056	7.840	131067	8.035
131080	8.230	132835	8.425
132828	7.855	131068	8.050
131081	8.245	131088	8.440
131057	7.870	*131069	8.065
131082	8.260	132836	8.455
*132829	7.885	*131070	8.080
*132830	8.275	132837	8.485
131058	7.900	131071	8.095
131083	8.290	131089	8.470
131059	7.915	131072	8.110
*132831	8.305	131090	8.500
*131060	7.930	131073	8.125
131084	8.320		

*These represent the most popular used spacers and each Bearing Spacer Kit contains qty 1 each.

Spicer Wheel Differential Case Kits

Dana introduced new style wheel differential cases beginning in mid Dec 2008. The new design differential cases have 4 extra "lube passage" holes that can be used in place of the original standard differential cases. Kits for these have not been released yet. When doing ratio changes or replacing original diff cases in the field, check the part numbers you are replacing to ensure you are installing or ordering the correct parts. See the chart below of what is "currently" being used for each model and ratio. A complete kit chart is shown on page 29.

Dana Model	Ratio	Flange Half Case	Plain Half Case	SERVICE KIT
D170 S170E Single Speed	3.07	131027	131479	513986
	3.21			
	3.42	131029	131478	513988
	3.58			
	3.73			
	3.91			
	4.10			
	4.30			
	4.56			
	4.78			
	5.25			
	5.38			
	5.57			
	6.14			
	6.83			
7.17				
S170S R170S Single Speed	3.07	131027	131479	513986
	3.21		131478	513987
	3.42	131029	131478	513988
	3.58			
	3.73			
	3.91			
	4.10			
	4.30			
	4.56			
	4.78			
	5.25			
	5.38			
	5.57			
	6.14			
	6.83			
7.17				

Wheel Differential Case

Dana Model	Ratio	Flange Half Case	Plain Half Case	SERVICE KIT		
D190 Single Speed	3.42	131027	131476	513990		
	3.58	131029	131476	513990		
	3.73					
	3.91	131029	131752	TBD		
	4.10					
	4.30					
	4.56					
	4.78					
	5.25					
	5.38				131476	513990
	5.57				131752	TBD
	6.14					
	6.83					
	7.17					
R190 S190 Single Speed	2.53	131027	131477	513989		
	2.69					
	2.87					
	2.93					
	3.07					
	3.21					
	3.42	131027	131760	TBD		
	3.58	131029	131760	TBD		
	3.73					
	3.91	131029	131759	TBD		
	4.10					
	4.30					
	4.56					
	4.78					
	5.25				131760	TBD
	5.38				131759	TBD
	5.57					
	6.14					
6.83						
7.17						
7.83						

Wheel Differential Case

Dana Model	Ratio	Flange Half Case	Plain Half Case	SERVICE KIT
D590 Double Reduction	4.75	131027	131476	TBD
	4.99	131029		
	5.19			
	5.44	131029	131752	
	5.70			
	5.98			
	6.34			
	6.65		131476	
	7.30			
	7.48		131752	
	7.75			
	8.55			
	9.51			
	9.97			
10.90				
R590 S590 Double Reduction	4.75	131029	131760	TBD
	4.99		131759	
	5.19			
	5.44			
	5.70			
	5.98			
	6.34		131760	
	6.65			
	7.30		131759	
	7.48			
	7.75			
	8.55			
	9.51			
	9.97			
10.90				

Wheel Differential Case Kit Contents:

Kit Part-NO	Flange Half (A)	Plain Half (B)	Ring Gear Bolts (C)	Ring Gear Bolt Kit
513986	131027	131479	131473 (qty-16)	504069 (contains qty 16 of 131473 bolts)
513987	131027	131478		
513988	131029	131478		
513989	131027	131477		
513990	131027	131476		
513991	131029	131476		
n/a	-----	131752		
n/a	-----	131759		
n/a	-----	131760		

Differential Lock Shift Parts - All Models

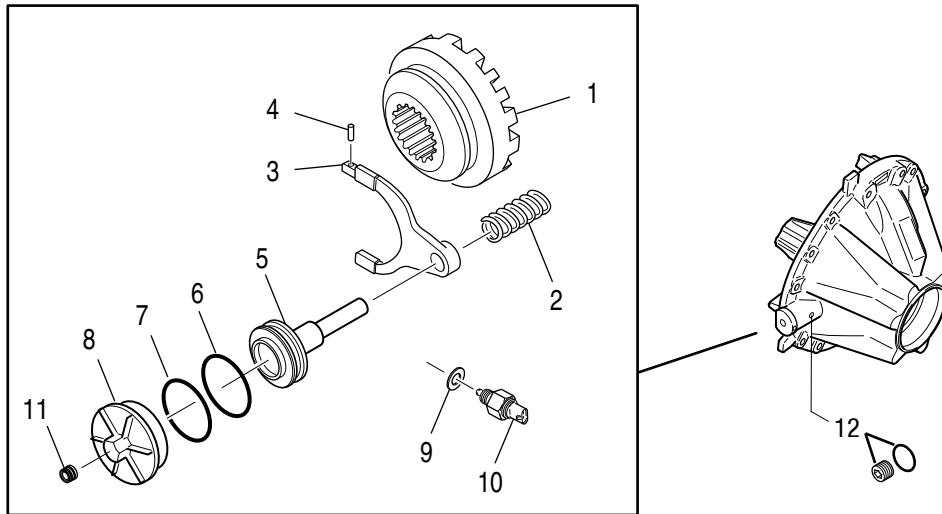

WHEEL DIFFERENTIAL LOCK ASSEMBLY

Item	Description	Qty	All Diff-Lock Models	Notes
Diff Lock Parts Conversion Kit - 190 Series only				See Note 1
Kit w/ 131099 Shift Fork (refer to chart next page)			512946	Includes items 1-10 and 512944 (131099)
Kit w/ 131101 Shift Fork (refer to chart next page)			512947	Includes items 1-10 and 512945 (131101)
Diff Lock Repair Kit			512895	Includes items 2, 5-8
1	Sliding Clutch	1	131104	
2	Spring	1	131102	
3	Shift Fork Assy	1	See chart next page	
			512944	Shift Fork 131099 NSS; includes item 4
			512945	Shift Fork 131101 NSS; includes item 4
4	Pin	1	210020	
5	Piston & Rod Assembly	1	131237	
6	O-Ring - Piston	1	210180	
7	O-Ring - Cap Cover	1	131665	replaces 220HH102, 131496
8	Piston Cover (Diff Lock Cap)	1	131096	
9	Washer	1	129034	
10	Switch	1	129035	
11	Plug - Carrier	1	127195	Use for Non Diff Lock Mdls
12	O-Ring & Plug Assy	1	131487	Use for Non Diff Lock Mdls

Note 1: The "170" Series carriers cannot be converted to Diff Lock. You must have the unique base carrier/cap that has the Diff Lock shift cylinder. You are required to purchase a replacement carrier. All "190" Series have the shift cylinder as part of the standard design.

Wheel Differential Case and Shift Fork Chart

Differential Lock Shift Fork & Diff Case Chart - All Models

Differential Lock Shift Forks vary by ratio and model. Dana made a assembly configuration change beginning in mid Dec 2008. It involved optimizing the best assembly combination of Splined Wheel Diff Cases and Shift Forks. When doing ratio changes, check the Shift Fork part number and diff cases part numbers you are replacing to help ensure you are installing or ordering the correct mated part(s). See the chart of "Matching Components" by "Model" below.

Dana Model	Ratio	Diff Lock Shift Fork ID#	Shift Fork Kit	Flange Half Case	Plain Half Splined Case	
D170D D170DP Single Speed	3.07	131101	512945	131029	131477	
	3.21			131027	131476	
	3.42			131029	131476	
	3.58				131476	
	3.73				131752	
	3.91					
	4.10				131476	
	4.30					
	4.56					
	4.78					
	5.25					
	5.38					
	5.57					
	6.14			131752		
6.83						
7.17						
R170D S170D Single Speed	3.07	131101	512945	131027	131476	
	3.21			131029		
	3.42			131027		
	3.58			131029	131752	
	3.73					
	3.91					
	4.10					
	4.30					
	4.56					
	4.78					
	5.25					
	5.38					
	5.57					131099
	6.14			131101	512945	131752
6.83						
7.17						

Wheel Differential Case and Shift Fork Chart

Dana Model	Ratio	Diff Lock Shift Fork ID#	Shift Fork Kit	Flange Half Case	Plain Half Splined Case
D190D Single Speed	3.42	131101	512945	131027	131476
	3.58			131476	
	3.73				
	3.91			131752	
	4.10				
	4.30				
	4.56				
	4.78				
	5.25			131476	
	5.38				
	5.57				
	6.14			131752	
	6.83				
7.17					
R190D S190D Single Speed	2.53	131101	512945	131027	131477
	2.69				
	2.87	131099	512944		
	2.93				
	3.07	131101	512945		
	3.21				
	3.31				
	3.42				
	3.58				
	3.73	131099	512944		
	3.91				
	4.10	131101	512945	131029	131759
	4.30				
	4.56				
	4.78				
	5.25				
	5.38	131099	512944	131760	
	5.57				
	6.14				
	6.83	131101	512945	131759	
7.17					
7.83					

Wheel Differential Case and Shift Fork Chart

Dana Model	Ratio	Diff Lock Shift Fork ID#	Shift Fork Kit	Flange Half Case	Plain Half Splined Case
D590D Double Reduction	4.75	131101	512945	131027	131476
	4.99			131029	
	5.19				
	5.44				
	5.70				
	5.98				131752
	6.34				
	6.65				
	7.30				131476
	7.48				
	7.75				
	8.55				
	9.51				131752
	9.97				
10.90					
R590D S590D Double Reduction	4.75	131101	512945	131029	131760
	4.99				131752
	5.19				
	5.44				131759
	5.70				131752
	5.98				
	6.34				131759
	6.65				131752
	7.30				
	7.48				131759
	7.75				
	8.55				131752
	9.51				
	9.97				131759
10.90					
S190DE High Entry	3.42	131101	512945	131029	131760
	3.58				131759
	3.73				
	3.91				
	4.10				
	4.30				131760
	4.56				
	4.78				131759
	5.25				
	5.38				
	5.57				
	6.14				131760
	6.83				
	7.17				131759

Housing and Output Shaft Assembly - Explode

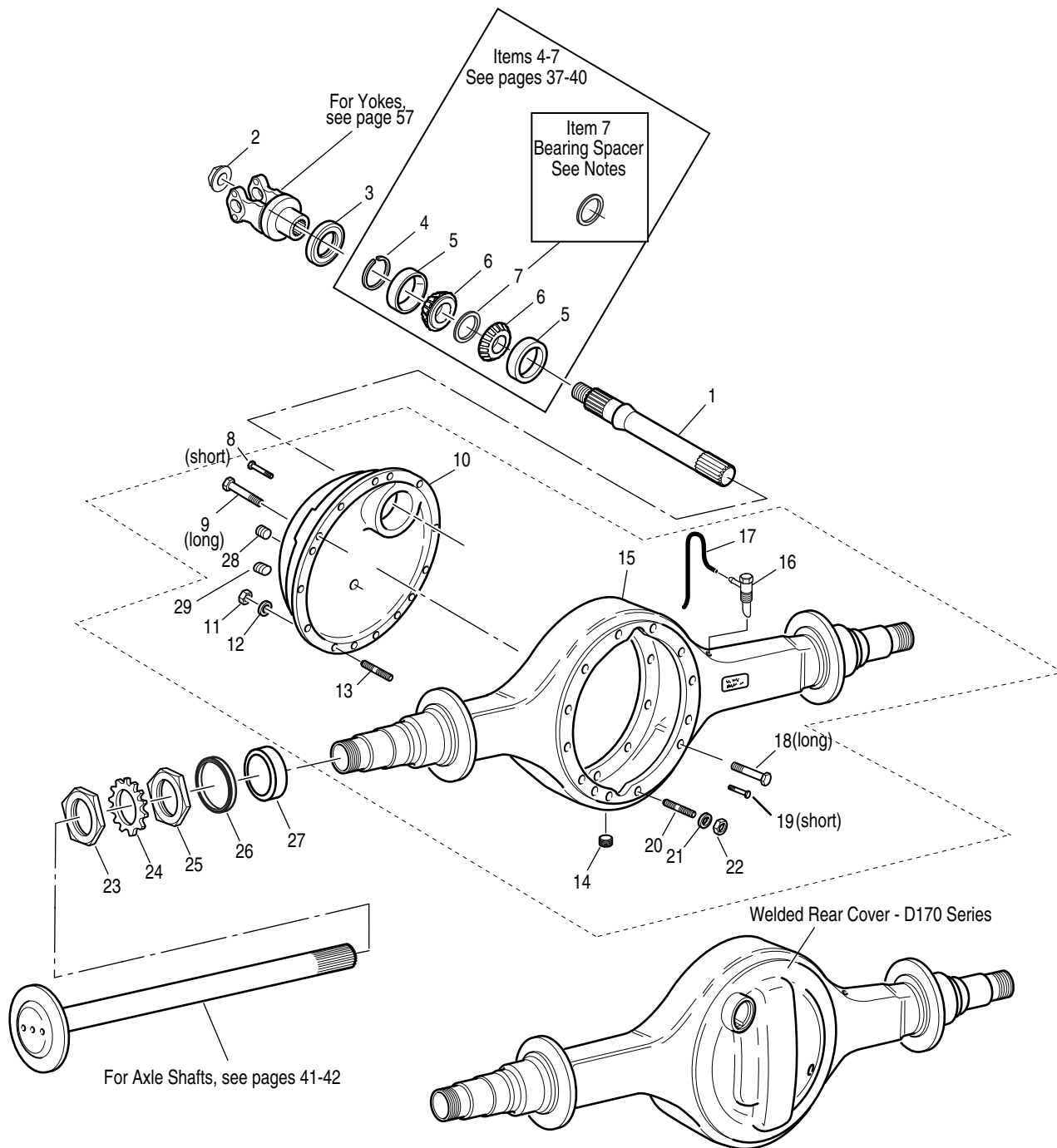

Housing and Output Shaft Assembly - Parts List

Item	Description	Qty	All Models	Notes
OUTPUT SHAFT KIT			512894	Includes items 1-2 - See Note 2
1	Output Shaft - 131536-NSS	1	Order Kit	Replaces 131468 - See Note 2
2	Output Shaft Nut	1	128049	
3	Output Seal	1	210737*	
4	Snap Ring	1	78937	
5	Bearing Cup	2	NOTE-3	see chart pages 37-40
6	Bearing Cone	2	NOTE-3	see chart pages 37-40
7	Bearing Spacer	1	NOTE-3	see chart pages 37-40
8	Rear Cover Capscrew - Short	4	131105	55 mm - D190 only
9	Rear Cover Capscrew - Long	8	131375	70 mm - D190 only
10a	D190 Housing Cover Kit	1	504061	Cover # 302576-NSS - 12 hole (see chart pg-40)
10b	S190 Housing Cover Kit	1	514322	Cover # 302704-NSS - 14 hole (see chart pg-40)
10c	S590 Housing Cover Kit	1	504025	Cover # 302622-NSS - 12 hole (see chart pg-40)
11	Rear Cover Nut	2	127567	D190 only
12	Washer - Rear Cover	2	130877	D190 only
13	Stud - Double Ended	2	132927	D190 only - 80mm
14	Drain Plug	1	54254	3/4" magnetic
15	Axle Housing	1	NOTE-3	Contact the OEM for specific part number by axle bom
U-TUBE BREATHER KIT			507162	Includes items 16-17
16	Breather Assy-NSS	1	302706	Order kit 507162
17	Breather Hose & Clamp-NSS	1	129340	Order kit 507162
18	Carrier Capscrew - Long	A/R	131106	Carrier to housing (see kit chart pg 36) - 85mm
19	Carrier Capscrew - Short	A/R	131105	Carrier to housing (see kit chart pg 36) - 55 mm
20	Stud - double ended	2	132927	Carrier to housing - 80mm
21	Washer	2	130877	Carrier to housing
22	Nut	2	127567	Carrier to housing
23	Spindle Nut - Outer	2	119881	
24	Locking Ring	2	119883	
25	Spindle Nut - Inner	2	119882	
26	Oil Seal	1	304446	190 & 590 models only - part not illustrated
27	Spindle Sleeve	1	304447	190 & 590 models only - part not illustrated
28	Fill Plug	1	129492	3/4" magnetic - All Models
29	Temperature Sensor Plug	1	90898	1/2" magnetic - All Models
30	Loctite	1	129293	Part not illustrated
31	RTV Sealant	1	107276S	Part not illustrated
30	Bearing Spacer	1	139979	See Note 3

Note 1: Refer to Dana bulletin HAXL-PNI-017 for complete bearing change details

Note 2: The 131468 output shaft included a 131355 output shaft washer. This washer is NLA and replaced by none. Shaft p/n 131536 does not use a washer, do not use 131355 with shaft p/n 131536.

Note 3: A permanent change to the output shaft bearing configuration began late Oct 2011. A 139979 housing spacer was used on some interim builds from June 2010 thru October 2011. See reference charts on page 37-40 for details. Dana bulletin HAXL-TEC-11.1 also contains complete details.

Summary of Kits & Assemblies

Description	Kit Part #	Notes
Output Shaft Bearing Kit-Original Builds	513877	Contents shown on next page (Note 1)
Output Shaft Bearing Kit-Interim Builds	504054	Contents shown on next page (Note 1)
Output Shaft Bearing Kit-New Builds	504060	Contents shown on next page (Note 1)
Output Shaft Kit	512894	Includes items 1 and 2
D-Housing Cover Hardware Kit	513351	Includes items 8-9, 11-12
Axle Housing Hardware Kit - Forward	512896	Includes items 18-22, 26-27
Axle Housing Hardware Kit - Rear	512897	Includes items 18-19, 26-27
U-Tube Breather Kit	507162	Includes items 16 and 17

Note 1: Refer to Supplemental Information on Output Shaft Parts Change and Bearing Cone & Cup Change on pages 36-40 and 43-45

Axle Housing Fastener Hardware Kits

D-Housing Cover or Bolt-On Cover Fastener Kit

Model: D190, S190, D590, S590, R590

Dana# 513351

Qty	P/N	Description
4	131105	Capscrew - 55mm
8	131375	Capscrew - 70mm
2	132927	Stud - dbl ended
2	127567	Nut
2	130877	Washer
1	129293	Loctite .8ml tube
1	107276S	RTV tube

Carrier-To-Housing Fastener Kit

Models: D170, D190, S190DE, S590, R590

Dana# 512896

Qty	P/N	Description
9	131105	Capscrew - 55mm
3	131106	Capscrew - 85mm
2	132927	Stud - dbl ended
2	127567	Nut
2	130877	Washer
1	129293	Loctite .8ml tube
1	107276S	RTV tube

Carrier-To-Housing Fastener Kit

Models: R170, R190, S170, S190

Dana# 512897

Qty	P/N	Description
10	131105	Capscrew - 55mm
4	131106	Capscrew - 85mm
1	129293	Loctite .8ml tube

D170 / D190 Output Shaft Bearing Race Parts Change Information

Dana made significant design change to the output shaft bearing components in Oct 2011. Details are shown below and in bulletin HAXL-TEC-11.1 Exact implementation dates for product changes can vary by OE. Additionally replacement of original product in the field by customers from previous repairs could be possible. Replacement parts should always be confirmed by identifying the original removed parts before parts are ordered or installed.

- **WARNING: DO NOT MIX Parts!** Mixing of parts could cause pre-mature failure to the output shaft bearings and associated parts. Check compatibility of parts before final assembly!

Chart-N

New Axle Housings w/ New Brg Cups and Snap Ring Groove Location Change:

Use kit 504060 when replacing the bearing parts from new build configurations or when ordering any of the new design axle housings with the relocated snap ring groove. New design housings are made AFTER October 24th 2011. Refer to the D170 Axle Housing Replacement Chart on pages 38-39.

Output Shaft Bearing Kit: 504060

Item	Qty Per Description	Axle	Part-No.	Notes
1	Snap Ring .109"	1	134322	New Design Dim: .109" x 4.22"
2/3	Bearing Cup	2	139980	Cup ID# NP910345
4	Bearing Cone	2	131211	Cone ID# NP197868

Chart-O

Original Design Axle Housings w/ Original Brg Cup and Original Snap Ring Groove Location:

Use kit 513877 when replacing the bearing parts from any original design axle housing or bolt on cover. Original production housings and covers made from 2003 thru June 2010.

Output Shaft Bearing Kit: 513877

Item	Qty Per Description	Axle	Part-No.	Notes
1	Snap Ring	1	78937	Original Design Dim: .093" x 4.14"
2/3	Bearing Cup	2	131212	Cup ID# NP802507
4	Bearing Cone	2	131211	Cone ID# NP197868

Chart-I

Interim Build Configuration – Original Axle Housing w/ Repositioned Snap Ring Groove and use of a Axle Housing Spacer:

The 504054 kit shown below was released and used when replacing the bearing parts from axles built with parts used on an interim basis. From June 2010 thru Oct 24th 2011 axle assemblies used a bearing spacer in addition to the bearing cup combination of 139980/131212. The snap ring groove location change was introduced but required the use of the spacer too. Check individual component identification or confirm vehicle build or serial number information if available. This kit contains a replacement output nut and oil seal.

NOTE: The new 504060 kit can be used as an alternate replacement for the 504054 parts kit, but the housing spacer 139979, inner bearing cup 131212 and original snap ring 078937 MUST NOT be used. Use only the parts supplied in the 504060 kit.

Output Shaft Bearing Kit: 504054

Item	Qty Per Description	Axle	Part-No.	Notes
1	Snap Ring	1	78937	Dim: .093" x 4.14"
2	Bearing Cup	1	131212	Inner Cup ID# NP802507
3	Bearing Cup	1	139980	Outer Cup ID# NP910345
4	Bearing Cone	2	131211	Cone ID# NP197868
5	Housing Spacer	1	139979	Interim Housing Spacer
6	Output Nut	1	128049	Output Nut
7	Oil Seal	1	210737	Thru-Shaft Seal

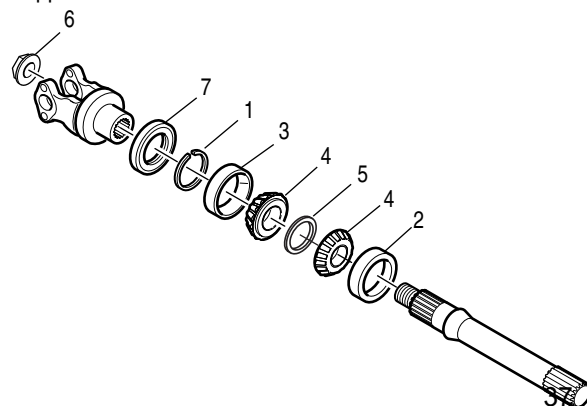

D170 AXLE HOUSING REPLACEMENT CHART

The chart below shows the supersession of all D170 design axle housings as detailed in Dana bulletin HAXL-TEC-11.1.

NOTE: All NEW axle housings released for service by Dana are now sold less the traditional miscellaneous hardware parts such as studs, washers, capscrews, plugs and breather parts. These parts are available and sold in kit form and are shown on pages 36 of this ipl.

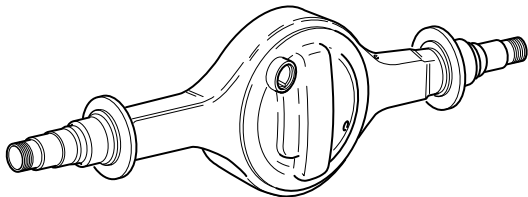

NOTE: OE Dealers should now stock new output shaft bearing Kit 504060. If servicing or using any of the new service axle housings shown in the chart below, the bearing components in kit 504060 must also be used.

Original Housing Part-No.	Original Service Part-No.	Interim Housing Part-No.	New Production Part-No.	For Service Order Part-No.
321980	321981	324026	324252	324252
322454	n/a	324028	324253	324270
322482	n/a	324030	324254	324252
322600	n/a	324032	324255	call dana
322664	n/a	324034	324256	call dana
322668	n/a	324036	324257	call dana
322676	n/a	324038	324258	call dana
322706	322707	324040	324259	324259
322716	n/a	324042	324260	call dana
322742	n/a	324044	324261	call dana
322746	322747	324046	324262	324262
322750	n/a	324048	324263	call dana
322754	n/a	324050	324264	call dana
322776	322777	324052	324265	324265
322782	322783	324054	324266	324266
322792	n/a	324056	324267	call dana
322814	n/a	324058	324268	call dana
322882	n/a	324060	324269	324252
322890	322891	324062	324270	324270
322894	322895	324064	324271	324271
322898	322899	324066	324272	324272
322902	n/a	324068	324273	call dana
322906	n/a	324070	324274	call dana
322952	n/a	324072	324275	324275
322956	322957	324074	324276	324276
322960	322961	324076	324277	324277
322970	322971	324078	324278	324278
322974	322975	324080	324279	324279
322978	n/a	324082	324280	call dana
322986	322987	324086	324282	324282
322990	n/a	324084	324281	324252
322992	322993	324086	324282	call dana
322994	n/a	324088	324283	324270
323008	n/a	324090	324284	324284
323028	n/a	324092	324285	324271

Original Housing Part-No.	Original Service Part-No.	Interim Housing Part-No.	New Production Part-No.	For Service Order Part-No.
323110	n/a	324094	324286	324275
323114	n/a	324096	324287	call dana
323118	n/a	324098	324288	call dana
323226	n/a	324100	324289	call dana
323238	n/a	324102	324290	324290
323276	323277	324104	324291	324291
323304	n/a	324106	324292	324252
323319	n/a	324107	324293	324271
323336	n/a	324108	324294	call dana
323337	n/a	324109	324295	call dana
323344	n/a	324110	324296	324270
323347	502038	324111	324297	324297
323351	502078	324112	324298	324298
323356	n/a	324113	324299	call dana
323358	n/a	324114	324300	324252
323361	n/a	324115	324301	call dana
323376	n/a	324116	324302	call dana
323378	n/a	324117	324303	call dana
323380	n/a	324118	324304	call dana
323382	n/a	324119	324305	call dana
323384	n/a	324120	324306	call dana
323386	n/a	324148	324307	call dana
323425	n/a	324149	324308	call dana
323427	n/a	324150	324309	call dana
323428	n/a	324151	324310	call dana
323430	n/a	324152	324311	324270
323433	n/a	324153	324312	324312
323435	n/a	324154	324313	call dana
323439	502046	324155	324314	324314
323455	n/a	324156	324315	call dana
323457	502045	324157	324316	324316
323459	n/a	324158	324317	call dana
323472	n/a	324159	324318	call dana
323474	n/a	324160	324319	call dana
323485	322793	324161	324320	324320

D170 / D190 Output Shaft Bearing Race Parts Change Information

Original Housing Part-No.	Original Service Part-No.	Interim Housing Part-No.	New Production Part-No.	For Service Order Part-No.	Original Housing Part-No.	Original Service Part-No.	Interim Housing Part-No.	New Production Part-No.	For Service Order Part-No.
323499	n/a	324162	324321	call dana	323986	n/a	324186	324345	call dana
323505	n/a	324163	324322	call dana	323994	n/a	324187	324346	call dana
323517	n/a	324164	324323	324252	323402	n/a	324189	324347	call dana
323519	n/a	324165	324324	324324	323684	n/a	324200	324348	call dana
323530	n/a	324166	324325	call dana	323801	n/a	324201	324349	call dana
323532	n/a	324167	324326	324326	324000	n/a	324202	324350	call dana
323561	502020	324168	324327	324327	322796	n/a	324203	324351	call dana
323567	n/a	324169	324328	call dana	n/a	n/a	324004	324352	call dana
323568	n/a	324170	324329	call dana	n/a	n/a	324005	324353	call dana
323649	n/a	324171	324330	call dana	n/a	n/a	324006	324354	call dana
323689	n/a	324172	324331	call dana	n/a	n/a	324007	324355	call dana
323712	n/a	324173	324332	call dana	n/a	n/a	324008	324356	call dana
323727	n/a	324174	324333	call dana	n/a	n/a	324009	324357	call dana
323777	n/a	324175	324334	324271	n/a	n/a	324010	324358	call dana
323853	n/a	324176	324335	call dana	n/a	n/a	324011	324359	call dana
323866	n/a	324177	324336	call dana	n/a	n/a	324122	324360	call dana
323867	n/a	324178	324337	call dana	n/a	n/a	324123	324361	call dana
323884	502062	324179	324338	324338	n/a	n/a	324124	324362	call dana
323913	n/a	324180	324339	call dana	n/a	n/a	324125	324363	call dana
323931	n/a	324181	324340	call dana	n/a	n/a	324126	324364	call dana
323956	n/a	324182	324341	call dana	n/a	n/a	324127	324365	call dana
323973	n/a	324183	324342	324342	n/a	n/a	324128	324366	call dana
323976	n/a	324184	324343	324343	n/a	n/a	324129	324367	call dana
323979	n/a	324185	324344	call dana					

D190 AXLE HOUSING COVER CHANGE

The D190 models have a bolt on axle housing cover which is now replaced by new cover part number 134324 which has the new relocated snap ring groove. The original cover 302576 and kit part number 513581 are nla and superseded to kit 504061. The 504061 kit contains the items listed in the chart below

D190 - AXLE HSG COVER & BRG PARTS KIT: 504061

Item	Description	Qty Per Axle	Part-No.	Notes
1	COVER - AXLE HOUSING	1	134324	Cover with relocated snap ring groove D190 mdl's
2	PLUG - COVER	1	90898	1/2"
3	PLUG - LUBE FILL	1	129492	3/4" non magnetic
4	BEARING CONE	2	131211	
5	SNAP RING .109"	1	134322	Use with new design cover 134324
6	BEARING CUP	2	139980	Use cups with new design cover 134324

S190 - AXLE HSG COVER KIT: 514322

Item	Description	Qty Per Axle	Part-No.	Notes
1	COVER - AXLE HOUSING	1	302704	(cover not illustrated) S190 mdl's only
2	PLUG - COVER	1	90898	1/2"
3	PLUG - LUBE FILL	1	129492	3/4" non magnetic
7	CAPSCREW - LONG	8	131375	70mm
8	CAPSCREW - SHORT	6	131105	55mm
9	WASHER	14	130877	

S590 - AXLE HSG COVER KIT: 504025

Item	Description	Qty Per Axle	Part-No.	Notes
1	COVER - AXLE HOUSING	1	302622	(cover not illustrated) S590 mdl's only
2	PLUG - COVER	1	90898	1/2"
3	PLUG - LUBE FILL	1	129492	3/4" non magnetic

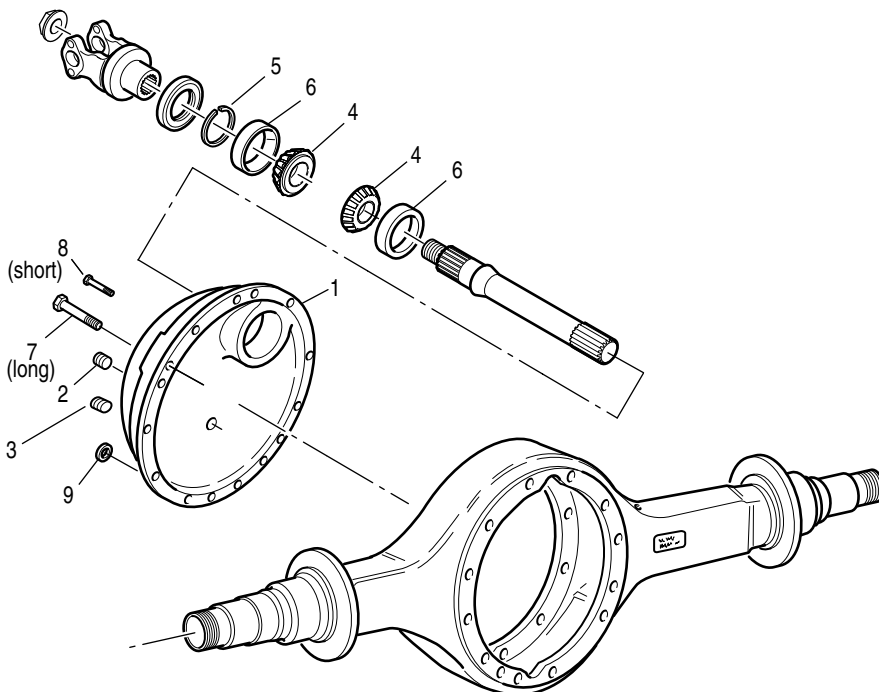

Axle Shafts

Dana D170 and D190 series axle shafts are used in “sets,” and are shown as sets in the chart below. They have unequal shaft lengths and are “location specific” and/or “Wheel Equipment specific.” When replacing the axle shafts, locate the axle shaft part number in the chart or select the correct axle shaft using the dimensional information. Always verify part numbers before placing your order.

DO NOT MISPLACE AXLE SHAFTS FROM THEIR INTENDED LOCATION.

Axle Shafts - For Standard Models

Part No.	Qty	Spline	Body O.D.	Shaft Length	Spline Length	BC Dim.	Flange O.D.	Flange Holes
Models: D/R170, S170								
131428	1	46	2.06	37.000	3.70	7.000	8.500	.948-TPR
131429	1	46	2.06	46.000	3.70	7.000	8.500	.948-TPR
131804	1	46	2.06	45.150	3.70	7.000	8.500	.773-STR
131805	1	46	2.06	36.150	3.70	7.000	8.500	.773-STR
Models: D/R190, S190, D/S590, S170E, S190E								
131246	1	46	2.25	37.000	3.70	7.000	8.500	.948-TPR
131247	1	46	2.25	46.000	3.70	7.000	8.500	.948-TPR
131516	1	46	2.25	45.150	3.70	7.000	8.500	.948-TPR
131517	1	46	2.25	37.716	3.70	7.000	8.500	.948-TPR

Axle Shaft - For Diff Lock Models

Part No.	Qty	Spline	Body O.D.	Shaft Length	Spline Length	BC Dim.	Flange O.D.	Flange Holes
Models: D/R170D, S170D, D/R190D, S190D, D590D, S590D, S190DE								
131245	1	46	2.25	46.000	11.50	7.000	8.500	.948-TPR
131246	1	46	2.25	37.000	3.70	7.000	8.500	.948-TPR
131740	1	46	2.25	45.150	11.50	7.000	8.500	.948-TPR
131741	1	46	2.25	36.150	3.70	7.000	8.500	.948-TPR
131719	1	46	2.25	47.150	11.50	7.244	8.500	.948-TPR
131720	1	46	2.25	38.425	3.70	7.244	8.500	.948-TPR
131806	1	46	2.25	45.150	11.50	7.000	8.500	.773-STR
131807	1	46	2.25	36.150	3.70	7.000	8.500	.773-STR

Axle Shaft - Wide Track Models (See Note 2)

Part No.	Qty	Spline	Body O.D.	Shaft Length	Spline Length	BC Dim.	Flange O.D.	Flange Holes
Models: D/R170D, S170D, D/R190D, S190D, D590D, S590D, S190DE								
131503	1	46	2.25	48.835	11.50	7.000	8.500	.948-TPR
131504	1	46	2.25	39.835	3.70	7.000	8.500	.948-TPR
131717	1	46	2.25	46.949	11.50	7.244	8.500	.948-TPR
131718	1	46	2.25	38.898	3.70	7.244	8.500	.948-TPR
131721	1	46	2.25	48.425	11.50	7.244	8.500	.948-TPR
131722	1	46	2.25	39.331	3.70	7.244	8.500	.948-TPR
131721	1	46	2.25	48.425	11.50	7.244	8.500	.948-TPR
131723	1	46	2.25	40.394	3.70	7.244	8.500	.948-TPR
131724	1	46	2.25	50.945	11.50	7.244	8.500	.948-TPR
131725	1	46	2.25	42.894	3.70	7.244	8.500	.948-TPR
131726	1	46	2.25	53.445	11.50	7.244	8.500	.948-TPR
131727	1	46	2.25	45.394	3.70	7.244	8.500	.948-TPR
131750	1	46	2.25	49.291	11.50	7.244	8.500	.948-TPR
131751	1	46	2.25	40.196	3.70	7.244	8.500	.948-TPR
134052	1	46	2.25	50.154	11.50	7.000	8.500	.948-TPR
134054	1	46	2.25	41.154	3.70	7.000	8.500	.948-TPR

Note 1: When doing "Upgrades" from Non-Diff Lock applications to "Diff Lock" in the 170 series, both axle shafts must be replaced by the 2.25" body diameter design, refer to the chart to select the correct axle shafts.

Note 2: Original axle shaft part numbers 132813 & 132814 were discontinued in 2007 and replaced by new axle shafts. For detailed information on that change refer to dana bulletin ABIB-0703.

Bearing Kits

Forward Carrier Models

		514238	514011	504074	514012	504072	504073
Part Description	Qty	D170S	D170D	S170E	D190S D190D	D590 D590D	S590, R590 S590D, R590D S190E, S190DE
Brg Cup - Threaded - Plain Half	1	131044	131048	131044	131048	131048	131048
Bearing Cone - Diff Plain Half	1	131041	131042	131041	131042	131042	131042
Brg Cup - Threaded - Flg Half	1	131044	131044	131044	131044	131044	131044
Brg Cone - Diff Flg Half	1	131041	131041	131041	131041	131041	131041
Bearing - Pinion Pilot	1	-----	-----	-----	129947	129947	129947
Brg Cone - Inner Pinion	1	139968	139968	139968	139968	139968	139968
Brg Cup - Inner Pinion	1	139969	139969	139969	139969	139969	139969
Brg Cup - Outer Pinion	1	139972	139972	139972	139972	139972	139972
Brg Cone - Outer Pinion	1	139971	139971	139971	139971	139971	139971
Brg Cup - O/P Side Gear	1	139976	139976	139976	139976	139976	139976
Brg Cone - O/P Side Gear	1	139975	139975	139975	139975	139975	139975
Brg Cone - Input Shaft	1	139973	139973	139973	139973	139973	139973
Brg Cup - Input Adjuster	1	139974	139974	139974	139974	139974	139974
Input Shaft Washer	1	132440	132440	-----	132440	132440	-----
V-Ring	1	131333	131333	-----	131333	131333	-----
Oil Seal - Output	1	210737	210737	-----	210737	-----	-----
Oil Seal - Input Location	1	134323	134323	134323	134323	134323	134323
Nut - Input Shaft	1	131095	131095	-----	131095	-----	-----
Loctite Tube	1	129293	129293	-----	129293	-----	-----
Gasket Compound - RTV	1	107276S	107276S	107276S	107276S	107276S	107276S

Single & Rear-Rear Carrier Models

		514013	514014	514240	514015	514015	514016
Part Description	Qty	R170S S170S 2.69-3.91	R170S S170S 4.10-7.17	R170D S170D 4.10-7.17	R170D S170D 2.69-3.91	R190 S190 2.53-4.78	R190 S190 5.25-7.83
Brg Cup - Threaded - Plain Half	1	131044	131044	131048	131048	131048	131048
Brg Cone - Diff Plain Half	1	131041	131041	131042	131042	131042	131042
Brg Cup - Threaded - Flg Half	1	131044	131044	131044	131044	131044	131044
Brg Cone - Diff Flg Half	1	131041	131041	131041	131041	131041	131041
Bearing - Pinion Pilot	1	129947	-----	-----	129947	129947	126187
Brg Cone - Inner Pinion	1	139968	139968	139968	139968	139968	139968
Brg Cup - Inner Pinion	1	139969	139969	139969	139969	139969	139969
Brg Cup - Outer Pinion	1	139969	139969	139969	139969	139969	139969
Brg Cone - Outer Pinion	1	139970	139970	139970	139970	139970	139970
Loctite Tube	1	129293	129293	129293	129293	129293	129293
Nut - R-Pinion	1	131095	131095	131095	131095	131095	131095
Oil Seal - R-Pinion	1	134323	134323	134323	134323	134323	134323
Gasket Compound - RTV	1	107276S	107276S	107276S	107276S	107276S	107276S

Note 1: Important bearing changes began in February 2012, refer to Dana bulletin HAXL-PNI-017 for complete details. See www.spicerparts.com/literature

Carrier Bearing Cup and Cone Product Change

Beginning February 2012 Dana began implementing the use of new design bearing cups and cones in production carriers. Refer to Dana published bulletin# HAXL-PNI-017. The changes outlines in that bulletin are summarized below. "BEARING NOTE" references are shown thruout this parts catalogue and are done to help customers understand the impact of all parts involved and to mizimize any potential mixing of bearing parts from different suppliers.

Dana Bearing Guidelines:

- Bearings are manufactured and used in sets to maximize full life of the product
- NOT using SPECIFIED bearings in Dana carriers can create potential noise issues or lead to premature bearing failures and affect the warranty of product
- Mixing of bearing cups and cones can create potential noise issues or lead to premature bearing failures
- New and Old bearing cones and cups are manufactured by different suppliers
- Superseding OLD individual part numbers directly to the NEW individual part numbers could lead to mixing of parts that could lead to potential failures. DO NOT MIX CONES AND CUPS MANUFACURED BY DIFFERENT SUPPLIERS
- Spicer® service kit contents will always contain mating cones and cups

Individual Bearing Supersession List

Individual bearings cones and cups are sold separately thru service.

Always use and install as matched sets, as noted below.

When stock of the individual original bearing part numbers are exhausted, use the new parts in SETS!

Dana Part-No.	Description	Replaced By	Bearing Parts Matched by Location
131050-nla	Bearing Cone	139968	Pinion Bearing - Inner
131051-nla	Bearing Cup	139969	Pinion Bearing - Inner/Outer
131052-nla	Bearing Cone	139970	Pinion Bearing - Outer
131202-nla	Bearing Cone	139971	Pinion Bearing - Outer
131203-nla	Bearing Cup	139972	Pinion Bearing - Outer
131205-nla	Bearing Cone	139973	Input Shaft Cone
131206-nla	Bearing Cup	139974	Input Shaft Cup
131208-nla	Bearing Cone	139975	Output Side Gear Cone
131209-nla	Bearing Cup	139976	Output Side Gear Cup
131211-nla	Bearing Cone	139977	Output Shaft Cone
131212-nla	Bearing Cup	139978	Output Shaft Cup

Bearing Kit Information

- For the service kits below - the bill of material changes will be done on a running basis.
- The bill of materials will began changing in late May 2012.

Dana Part-No.	Description	Model	Ratios
514011	Bearing Kit	D170D	all ratios
514012	Bearing Kit	D190, D190D, D590, D590D	all ratios
514238	Bearing Kit	D170	all ratios
514013	Bearing Kit	R170, S170	2.69-3.91
514014	Bearing Kit	R170, S170	4.10-7.17
514015	Bearing Kit	R170D, S170D	2.53-3.91
514015	Bearing Kit	R190, R190D, S190, S190D	2.53-4.78
514016	Bearing Kit	R190, R190D, S190, S190D	5.25-7.83
514240	Bearing Kit	R170D, S170D	4.10-7.17

Input Adjuster & Cup Assemblies

INPUT ADJUSTER & CUP ASSY:

Kits 514356 and 514357, that contain the Input Adjuster & Cup Assy., have been superseded by new service kit part numbers, 504066 and 504067

The new replacement kits will now contain the new Input Adjuster & Cup Assy's and the matching Input Bearing Cone.

Dana Part-No.	Description	Replacement Information
131205-nla	Bearing Cone	Replaced by new 139973
131685-nla	Input Adjuster & Cup Assy	Replaced by new 134354
514356-nla	Kit – Input Adjuster & Cover D190	Replaced by new 504066
514357-nla	Kit – Input Adjuster & Cover D170	Replaced by new 504067

Part-No **514356-nla now**
Desc **Kit - D190 Piloted I/P Cover**

Part-No.	Description	Qty
131687	cover - diff carrier	1
131692	stud	1
131374	capscrew - hex	12
131693	nut - hex	1
131685	input adjuster & cup assy	1

Part-No **504066**
Desc **Kit - Cvr and Input Adjuster D190**

Part-No.	Description	Qty
131687	cover - diff carrier	1
131692	stud	1
131374	capscrew - hex	12
131693	nut - hex	1
134354	input adjuster & cup assy	1
139973	brg cone	1

Part-No **514357-nla now**
Desc **Kit - D170 Piloted I/P Cover**

Part-No.	Description	Qty
131686	cover - diff carrier	1
131692	stud	1
131374	capscrew - hex	10
131693	nut - hex	1
131685	input adjuster & cup assy	1

Part-No **504067**
Desc **Kit - Cvr and Input Adjuster D170**

Part-No.	Description	Qty
131686	cover - diff carrier	1
131692	stud	1
131374	capscrew - hex	10
131693	nut - hex	1
134354	input adjuster & cup assy	1
139973	brg cone	1

Output Side Gear & Lube Pump Kit Changes

The 513876 Lube Pump Parts Kit shown below was discontinued and replaced by the new 504065 kit, but this kit will not include a "bearing cone". The bearing cones are in bearing kits and or can be purchased as a separate item.

The bearing cone # 131208 and the mating cup # 131209 are being discontinued and are replaced by 139975 bearing cone and matching 139976 cup.

IMPORTANT: When a replacement output shaft side gear bearing cone and its matching cup are required make sure they are used in sets. Using a bearing kit is always recommended, but customers can purchase individually, as needed. Be sure to use matching parts.

Dana Part-No.	Description	Replacement Information
513876-nla	Kit-Lube Pump Parts	Replaced by new 504065*
131208-nla	Bearing Cone	Replaced by new 139975
131209-nla	Bearing Cup	Replaced by new 139976

Part-No Desc	513876-nla now Kit - Lube Pump Parts	Qty
Part-No.	Description	Qty
131208	bearing cone	1
131368	lube pump	1
131466	output side gear	1
131541	spring pin	1

Part-No Desc	504065 Kit - OP Gear and Lube Pump	Qty
Part-No.	Description	Qty
131368	lube pump	1
131466	output side gear	1
131541	spring pin	1

*The New 504065 kit does not come with output shaft side gear bearing cone. Purchase separately.

Output Shaft Bearings and Kits

Individual output shaft bearing cones and cups are being replaced, see below for details

Service kit bill of material changes will simply be changed on a running basis.

Dana Part-No.	Description	Replacement Information
131211	Bearing Cone	Replaced by new 139977
131212	Bearing Cup	Replaced by new 139978
504054	Kit – D Hsg Repair	D170 models
504060	Kit – Output Shaft Bearing	D170, D190 models AFTER Nov 2011
504061	Kit – Hsg Cover and Brg Parts	D190 models
513877	Kit – Output Shaft Bearing	D170, D190 models BEFORE Nov 2011
514352	Kit – Hsg Repair D170	D170 models

Note: Important Axle housing and output shaft bearing part changes were made in October 2011. Refer to Dana bulletin HAXL-TEC-11.1 for details regarding those parts and kits.

D170(P) - Standard Carrier

**18" Ring Gear Diameter
Side Gear # 300GD101**

These new carrier units directly replace tandem forward models D40-170(P), D46-170(P), and D46-170H(P) with no modifications.

Ratio	Side Gear Spline	Non-Pump New Carrier	Pump New Carrier	Notes
3.07	46 Inv	681000	681034	
3.21	46 Inv	681001	681035	
3.42	46 Inv	681003	681037	
3.58	46 Inv	681004	681038	
3.73	46 Inv	681005	681039	
3.91	46 Inv	681006	681040	
4.10	46 Inv	681007	681041	
4.30	46 Inv	681008	681042	
4.56	46 Inv	681009	681043	
4.78	46 Inv	681010	681044	
5.25	46 Inv	681011	681045	
5.38	46 Inv	681012	681046	
5.57	46 Inv	681013	681047	
6.14	46 Inv	681014	681048	
6.83	46 Inv	681015	681049	
7.17	46 Inv	681016	681050	

R170 - Standard Carrier and No Spin Carrier

**18" Ring Gear Diameter
Side Gear # 300GD101
No Spin # 131882**

Note: Drive Axle Tag may read R46-170, S23-170

These new carrier units directly replace tandem rear-rear models R40-170, R46-170, and single axle models S21-170, S23-170, and S26-170 with no modifications.

Ratio	Side Gear Spline	New Service Carrier	No Spin Service Carrier
3.07	46 Inv	681183	
3.21	46 Inv	681184	
3.42	46 Inv	681186	
3.58	46 Inv	681187	
3.73	46 Inv	681188	
3.91	46 Inv	681189	
4.10	46 Inv	681190	
4.30	46 Inv	681191	681408
4.30	46 Inv	681394 Special 4.30 Gentech coach quiet ratio carrier	
4.56	46 Inv	681192	681409
4.78	46 Inv	681193	681410
5.25	46 Inv	681194	681411
5.38	46 Inv	681252	681412
5.57	46 Inv	681253	681382
6.14	46 Inv	681254	681413
6.83	46 Inv	681255	681414
7.17	46 Inv	681256	

D170D(P) - Diff Lock Carrier

18" Ring Gear Diameter
Side Gear # 300GD101

These new carrier units will directly replace tandem forward models D40-170D(P), D46-170D(P), and D46-170DH(P) with no modifications.

Ratio	Side Gear Spline	Non-Pump New Carrier	Pump New Carrier	Notes
3.07	46 Inv	681017	681051	
3.21	46 Inv	681018	681052	
3.42	46 Inv	681020	681054	
3.58	46 Inv	681021	681055	
3.73	46 Inv	681022	681056	
3.91	46 Inv	681023	681057	
4.10	46 Inv	681024	681058	
4.30	46 Inv	681025	681059	
4.56	46 Inv	681026	681060	
4.78	46 Inv	681027	681061	
5.25	46 Inv	681028	681062	
5.38	46 Inv	681029	681063	
5.63	46 Inv	681030	681064	
6.14	46 Inv	681031	681065	
6.83	46 Inv	681032	681066	
7.17	46 Inv	681033	681067	

R170D - Diff Lock Carrier

18" Ring Gear Diameter
Side Gear # 300GD101

Note: Drive Axle Tag may read R46-170D or S23-170D

These new carrier units directly replace tandem rear-rear models R40-170D, R46-170D, and single axle models S21-170D and S23-170D with no modifications.

Ratio	Side Gear Spline	New Service Carrier	Notes
2.69	46 Inv	681195	
2.87	46 Inv	681196	
2.93	46 Inv	681197	
3.07	46 Inv	681198	
3.21	46 Inv	681199	
3.31	46 Inv	681200	
3.42	46 Inv	681201	
3.58	46 Inv	681202	
3.73	46 Inv	681203	
3.91	46 Inv	681204	
4.10	46 Inv	681205	
4.30	46 Inv	681206	
4.56	46 Inv	681207	
4.78	46 Inv	681208	
5.25	46 Inv	681209	
5.38	46 Inv	681257	
5.57	46 Inv	681258	
6.14	46 Inv	681259	
6.83	46 Inv	681260	
7.17	46 Inv	681261	

D190 - Standard Carrier

**18.50" Ring Gear Diameter
Side Gear # 300GD101**

These new carrier units will directly replace tandem forward models D52-190, and D60-190 with no modifications. See Note 2.

Ratio	Side Gear Spline	New Service Carrier	Notes
3.42	46 Inv	681068	
3.58	46 Inv	681069	
3.73	46 Inv	681070	
3.91	46 Inv	681071	
4.10	46 Inv	681072	
4.30	46 Inv	681073	
4.56	46 Inv	681074	
4.78	46 Inv	681075	
5.25	46 Inv	681076	
5.38	46 Inv	681077	
5.57	46 Inv	681078	
6.14	46 Inv	681079	
6.83	46 Inv	681080	
7.17	46 Inv	681081	

R190 - Standard Carrier and No Spin Carrier

**18.50" Ring Gear Diameter
Side Gear # 300GD101**

Note: Drive Axle Tag may read R46-190 or S23-190

These new carrier units will directly replace tandem rear rear models R46-190, R52-190, and single axle models S23-190, S26-190, and S30-190 with no modifications.

Ratio	Side Gear Spline	New Service Carrier	No Spin Service Carrier
2.53	46 Inv	681288	
2.69	46 Inv	681210	
2.87	46 Inv	681211	
2.93	46 Inv	681212	
3.07	46 Inv	681213	
3.21	46 Inv	681214	
3.42	46 Inv	681216	
3.58	46 Inv	681217	
3.73	46 Inv	681218	
3.91	46 Inv	681219	
4.10	46 Inv	681220	
4.30	46 Inv	681221	
4.56	46 Inv	681222	
4.78	46 Inv	681223	
5.25	46 Inv	681224	
5.38	46 Inv	681225	681415
5.57	46 Inv	681226	681416
6.14	46 Inv	681227	681417
6.83	46 Inv	681228	681418
7.17	46 Inv	681229	
7.83	46 Inv	681230	

Note: Dana D190 Forward models come standard with lube pump. Serial tags for production axles may not carry the traditional "P" designation in the model identifier.

D190D - Diff Lock Carrier

18.50" Ring Gear Diameter
Side Gear # 300GD101

These new carrier units will directly replace tandem forward models D52-190D with no modifications.

Ratio	Side Gear Spline	New Service Carrier	Notes
3.42	46 Inv	681082	
3.58	46 Inv	681083	
3.73	46 Inv	681084	
3.91	46 Inv	681085	
4.10	46 Inv	681086	
4.30	46 Inv	681087	
4.56	46 Inv	681088	
4.78	46 Inv	681089	
5.25	46 Inv	681090	
5.38	46 Inv	681091	
5.57	46 Inv	681092	
6.14	46 Inv	681093	
6.83	46 Inv	681094	
7.17	46 Inv	681095	

R190D - Rear Rear w/ Diff Lock

18.50" Ring Gear Diameter
Side Gear #300GD101

Note: Drive Axle Tag may read R46-190D or S23-190D

These new carrier units will directly replace tandem forward models R46-190D, R52-190D, and single axle models S23-190D, S26-190D, and S30-190D with no modifications.

Ratio	Side Gear Spline	New Service Carrier	Notes
2.53	46 Inv	681478	
2.69	46 Inv	681231	
2.87	46 Inv	681232	
2.93	46 Inv	681233	
3.07	46 Inv	681234	
3.21	46 Inv	681235	
3.31	46 Inv	681236	
3.42	46 Inv	681237	
3.58	46 Inv	681238	
3.73	46 Inv	681239	
3.91	46 Inv	681240	
4.10	46 Inv	681241	
4.30	46 Inv	681242	
4.56	46 Inv	681243	
4.78	46 Inv	681244	
5.25	46 Inv	681245	
5.38	46 Inv	681246	
5.57	46 Inv	681247	
6.14	46 Inv	681248	
6.83	46 Inv	681249	
7.17	46 Inv	681250	
7.83	46 Inv	681251	

Note: Dana D190D Forward models with Diff Lock come standard with lube pump. Serial tags for production axles may not carry the traditional "P" designation in the model identifier.

S170R - Retarder Ready Carrier

18.00" Ring Gear Diameter
Side Gear # 300GD101

These new carrier units directly replace single axle models S23-170R, S26-170R and S30-170R with no modifications.

Ratio	Side Gear Spline	New Carrier	Notes
5.25	46 Inv	681349	

S170DR - Diff Lock w/Retarder Ready Option Carrier

18.00" Ring Gear Diameter
Side Gear # 300GD101

These new carrier units directly replace single axle models S23-170DR, S26-170DR and S30-170DR with no modifications.

Ratio	Side Gear Spline	New Carrier	Notes
5.25	46 Inv	681350	

S170FOBC - GenTech™ Quiet Gearing & Rolled Over

18.00" Ring Gear Diameter
Side Gear # 300GD101

These new carrier units directly replace single axle models S21-170FOBC, S23-170FOBC, S25-170FOBC with no modifications.

Ratio	Side Gear Spline	New Carrier	Notes
4.30	46 Inv	681394	

S190R - Retarder Ready Option Carrier

18.50" Ring Gear Diameter
Side Gear # 300GD101

These new carrier units will directly replace single axle models S30-190R with no modifications.

Ratio	Side Gear Spline	New Carrier	Notes
5.57	46 Inv	681479	

D590 - Double Reduction Carrier

18.50" Ring Gear Diameter
Side Gear # 300GD101

These new carrier units will directly replace forward models D46-590, D52-590, D60-590, D70-590 with no modifications.

Ratio	Side Gear Spline	New Carrier	Notes
4.75	46 Inv	681096	
4.99	46 Inv	681097	
5.19	46 Inv	681098	
5.44	46 Inv	681099	
5.70	46 Inv	681100	
5.98	46 Inv	681101	
6.34	46 Inv	681102	
6.65	46 Inv	681103	
7.30	46 Inv	681104	
7.48	46 Inv	681105	
7.75	46 Inv	681106	
8.55	46 Inv	681107	
9.51	46 Inv	681108	
9.97	46 Inv	681109	
10.90	46 Inv	681419	

D590D - Double Reduction w/Diff Lock Carrier

18.50" Ring Gear Diameter
Side Gear # 300GD101

These new carrier units will directly replace forward models D52-590D, D60-590D and D70-590D with no modifications.

Ratio	Side Gear Spline	New Carrier	Notes
4.75	46 Inv	681110	
4.99	46 Inv	681111	
5.19	46 Inv	681112	
5.44	46 Inv	681113	
5.70	46 Inv	681114	
5.98	46 Inv	681115	
6.34	46 Inv	681116	
6.65	46 Inv	681117	
7.30	46 Inv	681118	
7.48	46 Inv	681119	
7.75	46 Inv	681120	
8.55	46 Inv	681121	
9.51	46 Inv	681122	
9.97	46 Inv	681123	
10.90	46 Inv		Call for Availability

S590 - Double Reduction Carrier

18.50" Ring Gear Diameter
Side Gear # 300GD101

These are "Forward" carrier units by design. These carriers will directly replace single axle models called out as; S23-590, S26-590, S30-590, S35-590 and replace tandem models called out as; R46-590, R52-590, R60-590, R70-590 with no modifications.

Ratio	Side Gear Spline	New Carrier	Notes
4.75	46 Inv	681152	
4.99	46 Inv	681153	
5.19	46 Inv	681154	
5.44	46 Inv	681155	
5.70	46 Inv	681156	
5.98	46 Inv	681157	
6.34	46 Inv	681158	
6.65	46 Inv	681159	
7.30	46 Inv	681160	
7.48	46 Inv	681161	
7.75	46 Inv	681162	
8.55	46 Inv	681163	
9.51	46 Inv	681164	
9.97	46 Inv	681165	
10.90	46 Inv	681276	

S590D - Double Reduction with Diff Lock Carrier

18.50" Ring Gear Diameter
Side Gear # 300GD101

These are "Forward" carrier units by design. These carrier units will directly replace single axle models called out as; S23-590D, S26-590D, S30-590D and S35-590D and replace models called out as; R52-590D, R60-590D, R70-590D with no modifications.

Ratio	Side Gear Spline	New Carrier	Notes
4.75	46 Inv	681166	
4.99	46 Inv	681167	
5.19	46 Inv	681168	
5.44	46 Inv	681169	
6.34	46 Inv	681391	
6.65	46 Inv	681393	
8.55	46 Inv	681392	
10.90	46 Inv	681277	

Single Axle - High Entry Carriers

S170E - High Entry Carrier

18.00" Ring Gear Diameter
Side Gear # 300GD101

These are "Forward" carrier units by design. These carrier units directly replace single axle models called out as; S21-170E, S23-170E with no modifications.

Ratio	Side Gear Spline	New Carrier	Notes
3.07	46 Inv	681483	
3.21	46 Inv	681484	
3.31	46 Inv	681485	
3.42	46 Inv	681486	
3.58	46 Inv	681487	
3.73	46 Inv	681488	
3.91	46 Inv	681489	
4.10	46 Inv	681490	
4.30	46 Inv	681491	
4.56	46 Inv	681492	
4.78	46 Inv	681493	
5.25	46 Inv	681494	
5.38	46 Inv	681495	
5.57	46 Inv	681496	
6.14	46 Inv	681497	
6.83	46 Inv	681498	
7.17	46 Inv	681499	

S190DE - High Entry with Diff Lock Carrier

18.50" Ring Gear Diameter
Side Gear # 300GD101

These are "Forward" units by design. These carrier units directly replace single axle models called out as: S23-190DE, S26-190DE and S30-190DE with no modifications.

Ratio	Side Gear Spline	New Carrier	Notes
3.42	46 Inv	681138	
3.58	46 Inv	681139	
3.73*	46 Inv	681140	
3.91*	46 Inv	681141	
4.10	46 Inv	681142	
4.30	46 Inv	681143	
4.56	46 Inv	681144	
4.78	46 Inv	681145	
5.25	46 Inv	681146	
5.38	46 Inv	681147	
5.57	46 Inv	681148	
6.14*	46 Inv	681149	
6.83	46 Inv	681150	
7.17	46 Inv	681151	

S190E - High Entry Carrier

18.50" Ring Gear Diameter
Side Gear # 300GD101

These are "Forward" units by design. These carrier units will directly replace single axle models called out as; S23-190E, S26-190E and S30-190E with no modifications.

Ratio	Side Gear Spline	New Carrier	Notes
3.58	46 Inv	681125	
4.56	46 Inv	681130	
4.78	46 Inv	681131	
5.38	46 Inv	681133	
5.57	46 Inv	681134	
6.14	46 Inv	681135	
7.17	46 Inv	681137	

Gear and Pinion Kits

D170, D170D, S170E High Entry Models

Pinion Nut Part No. 131095

Ratio	Spicer Service Kit Part No.	Gear Part No.	Pinion P/N Part No.	Tooth
3.07	513882	131281	131250	43-14
3.21	513883	131282	131261	45-14
3.42	513885	131283	131253	41-12
3.58	513886	131284	131254	43-12
3.73	513887	131283	131255	41-11
3.91	513888	131284	131256	43-11
4.10	513889	131283	131257	41-10
4.30	513890	131284	131258	43-10
4.56	513891	131285	131259	41-9
4.78	513892	131286	131260	43-9
5.25	513893	131287	131261	42-8
5.38	513894	131288	131262	43-8
5.57	513595	131289	131263	39-7
6.14	513896	131288	131264	43-7
6.83	513897	131290	131265	41-6
7.17	613898	131288	131266	43-6

R170, R170D, S170, S170D

Pinion Nut Part No. 131095

Ratio	Spicer Service Kit Part No.	Gear Part No.	Pinion P/N Part No.	Tooth
2.87	513915-nla	131183	131148	43-15
3.07	513917	131183	131150	43-14
3.21	513918	131185	131151	45-14
3.31	513919-nla	131183	131152	43-13
3.42	513920	131186	131153	41-12
3.58	513921	131187	131154	43-12
3.73	513922	131186	131155	41-11
3.91	513923	131187	131156	43-11
4.10	513924	131186	131157	41-10
4.30	513925	131187	131158	43-10
4.30 BC	504024	131596	133800	43-10
4.56	513926	131188	131159	41-9
4.78	513927	131189	131160	43-9
5.25	513928	131190	131161	42-8
5.38	513929	131460	131456	43-8
5.57	513930	131461	131457	39-7
6.14	513931	131460	131458	43-7
6.83	513932	131462	131459	41-6
7.17	513933	131463	131475	43-6

D190, D190D, D/R590, D/R590D, S590, S590D, S190E High Entry Models

Pinion Nut Part No. 131095

Ratio (note 1)	Spicer Service Kit Part No.	Gear Part No.	Pinion P/N Part No.	Tooth
3.42 (4.75)	513899	131283	131267	41-12
3.58 (4.99)	513900	131284	131268	43-12
3.73 (5.19)	513901	131283	131269	41-11
3.91 (5.44)	513902	131284	131270	43-11
4.10 (5.70)	513903	131283	131271	41-10
4.30 (5.98)	513904	131284	131272	43-10
4.56 (6.34)	513905	131285	131273	41-9
4.78 (6.65)	513906	131286	131274	43-9
5.25 (7.30)	513907	131287	131275	42-8
5.38 (7.48)	513908	131288	131276	43-8
5.57 (7.75)	513909	131289	131277	39-7
6.14 (8.55)	513910	131288	131278	43-7
6.83 (9.51)	513911	131290	131279	41-6
7.17 (9.97)	513912	131288	131280	43-6
7.83 (10.90)	513913	131522	131521	47-6

Note 1: Ratios shown in parentheses are ratio callouts for "Double Reduction 590 models" which use a 1:39-1 helical reduction gearing.

R190S, R190D, S190S, S190D

Pinion Nut Part No. 131095

Ratio	Spicer Service Kit Part No.	Gear Part No.	Pinion P/N Part No.	Tooth
2.53	513934	131506	131505	43-17
2.69	513935	131191	131162	43-16
2.87	513936	131191	131163	43-15
2.93	513937	131192	131164	41-14
3.07	513938	131191	131165	43-14
3.21	513939	131193	131166	45-14
3.42	513941	131194	131168	41-12
3.58	513942	131195	131169	43-12
3.73	513943	131194	131170	41-11
3.91	513944	131195	131171	43-11
4.10	513945	131194	131172	41-10
4.30	513946	131195	131176	43-10
4.56	513947	131194	131174	41-9
4.78	513948	131195	131175	43-9
5.25	513949	131196	131176	42-8
5.38	513950	131197	131177	43-8
5.57	513951	131198	131178	39-7
6.14	513952	131197	131179	43-7
6.83	513953	131198	131180	41-6
7.17	513954	131197	131181	43-6
7.83	513955	131200	131182	47-6

Yokes & Flanges

To replace the driveline yoke on any of the Dana D170/190, R170/190 or S190 series choose from the chart below. Each Yoke Replacement kit below includes a new pinion nut along with very important installation instructions and torque figures.

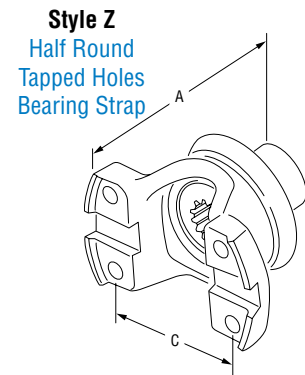
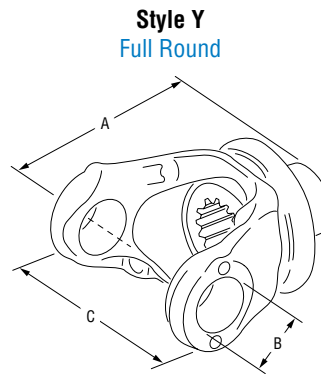
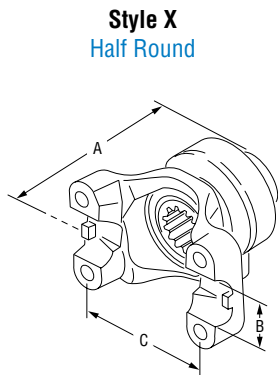

Input Yoke and Slinger Assembly - 49 Inv Spline

Driveshaft Part Number	Pinion Nut	Series	Joint Angle	Type	Production Reference Numbers
131447K *	131095	1810	30°	Half Rd.	6.5-4-5101-1
131448K *	131095	1810	30°	Full Rd.	6.5-4-5101
131446K *	131095	SPL250	25°	Half Rd.	250-4-1031-1
131520K	131095	1760	30°	Half Rd.	5005582
131530K	131095	1710	30°	Full Rd.	5008438
131519K	131095	1710	30°	Half Rd.	5008439
132863K	131095	SPL170	26.5°	Half Rd.	5008444, 5005217
132931K	131095	SPL170	42°	Half Rd.	5008461

Output Yoke and Slinger Assembly - 41 Inv Spline

Driveshaft Part Number	Pinion Nut	Series	Joint Angle	Type	Production Reference Numbers
131449K *	128049	1710	38°	Full Rd.	6-4-10301
131450K *	128049	1710	39°	Full Rd.	6-4-10301-1
131451K *	128049	SPL170	45°	Half Rd.	170-4-1901-1

Rear Pinion Yoke and Slinger Assembly - 49 Inv Spline

Driveshaft Part Number	Pinion Nut	Series	Joint Angle	Type	Production Reference Numbers
131442K *	131095	1710	30°	Full Rd.	6-4-10291
131439K	131095	1710	45°	Full Rd.	6-4-10311
131437K *	131095	1710	30°	Half Rd.	6-4-10291-1
131438K *	131095	1710	45°	Half Rd.	6-4-10311-1
131441K	131095	1760	30°	Full Rd.	6-3-4-1861
131440K	131095	1760	30°	Half Rd.	6-3-4-1861-1
131444K	131095	1810	30°	Full Rd.	6-5-4-5091
131443K	131095	1810	30°	Half Rd.	6-5-4-5091-1
131436K	131095	Comp Flg	---	Comp Flg	6-1-6281
131433K *	131095	SPL170	25°	Half Rd.	170-4-1891-1
131434K *	131095	SPL170	45°	Half Rd.	170-4-1911-1
131435K	131095	SPL250	25°	Half Rd.	250-4-1021-1

* Most popular - Spicer recommends keeping these in stock

Service Kits

Pinion Seal Driver Kit

Part Number 513349

Kit includes: 131471, 131472, 210749

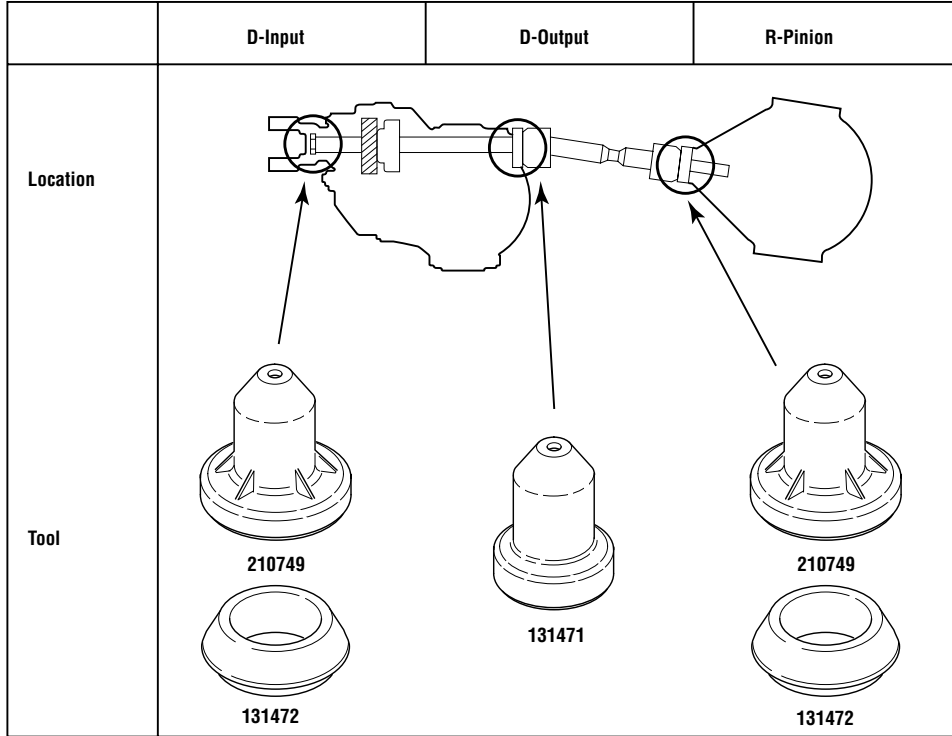

Wheel Differential Bearing Adjustment Kit

Part Number 513061

Dana Part-No	Description	Qty
130971	Adjusting Tool End	2
130997	Threaded Rod	1
130998	Nut	2
HN115	Flat Washer	2
SHAIS150	Information Sheet	1

Note: Spicer information and Instruction sheets can be found at: spicerparts.com/Literature

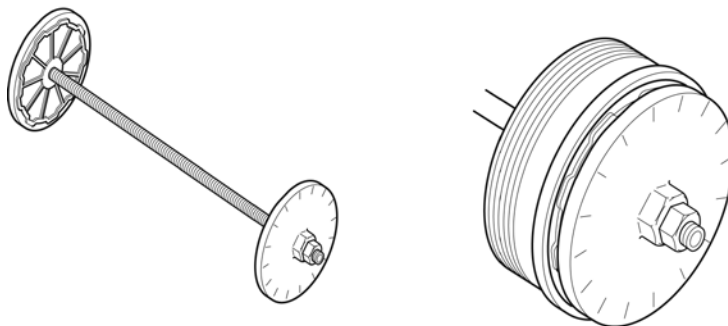

Spicer Service Kits Parts Listing

(Listed by "Part Description" alpha order)

Dana P/N	Description	Notes
512892	Air Lockout Repair Kit	All D170, 190 Models
512893	Air Lockout Repair Kit - Complete w/ Fork	Only D170 Models
504061	Axle Housing Cover & Brg Pts Kit	All D190 Models (has cover 134324 inside)
514322	Axle Housing Cover Kit	All S190 Models (has cover 302704 inside)
504025	Axle Housing Cover Kit	All S590 Models (has cover 302622 inside)
512896	Axle Hsg Hardware Kit - Forward Axle (carrier to hsg)	All D170, 190 Models
512897	Axle Hsg Hardware Kit - Rear Axle (carrier to hsg)	All R170/R190, S170, S190
513351	Axle Hsg Fastener Kit - (for D-Hsg bolt on covers)	All D190, S190, D/R590, S590 Models
514011	Bearing Kit - D170D	For D170D Diff Lock Models
514238	Bearing Kit - D170S	All Ratios
514012	Bearing Kit - D190S, D190D	All Ratios
504072	Bearing Kit - D590, D590D	All Ratios
504073	Bearing Kit - S/R590, S/R590D, S190E, S190DE	All Ratios
504074	Bearing Kit - S170E	All Ratios
514240	Bearing Kit - R170D, S170D	4.10-7.17 Ratios
514015	Bearing Kit - R170D, S170D, R190, S190S/D	2.69-3.91 (R170D/S170D) & 2.53-4.78 (R190/S190)
514013	Bearing Kit - R170S, S170S	2.69-3.91 Ratios
514014	Bearing Kit - R170S, S170S	4.10-7.17 Ratios
514016	Bearing Kit - R190, S190S/D	5.25-7.83 Ratios
513997	Carrier and Cap Kit - D170	D170
513998	Carrier and Cap Kit - D170D	D170D - Diff Lock Models
514001	Carrier and Cap Kit - D190/D190D	D190, D190D Diff Lock Models
513999	Carrier and Cap Kit - R170/S170	R170, S170
514000	Carrier and Cap Kit - R170D/S170D	R170D, S170D Diff Lock Models
514002	Carrier and Cap Kit - R190/R190D/S190D	R190, R190D, S190D Diff Lock Models
512947	Diff Lock Conversion Parts Kit (shift fork# 131101)	All Diff Lock Models (shift fork design varies by ratio)
512946	Diff Lock Conversion Parts Kit (shift fork# 131099)	All Diff Lock Models (shift fork design varies by ratio)
512945	Diff Lock Shift Fork (fork# 131101)	All Diff Lock Models (shift fork design varies by ratio)
512944	Diff Lock Shift Fork (fork# 131099)	All Diff Lock Models (shift fork design varies by ratio)
512895	Diff Lock Shift Parts Repair Kit	All Diff Lock Models
131345	Helical Gear & Bushing Assy	All D170, 190 Models
139965	IAD Assembly	All Models (replaces 131339)
504067	Input Cover & Adjuster Kit - D170	All D170 Models (replaces 513881 & 514357)
504066	Input Cover & Adjuster Kit - D190	Only D190 Models (replaces 513879 & 514356)
513839	Input Shaft Kit - Non Pump Models	Only D170 Non-Pump Models
513840	Input Shaft Kit - Pump Models	All D170P and All D190 Models
131340	Input Shaft & Helical Gear	High Entry S170E & S190E Models

Dana P/N	Description	Notes
504065	Lube Pump & Output Side Gear Kit	All D170P and D190 Pump Models (replaces 513876)
513880	Manifold Parts Kit - Non Pump Models	Only D170 Non-Pump Models
513878	Manifold Parts Kit - Pump Models	All D170P and All D190 Pump Models
131882	No Spin Diff Assy 46 Inv	All Approved D/R170, D/R190 Models
513877	Output Shaft Brg Kit	All D170, 190 Models - Original Builds Only
504054	Output Shaft Brg Kit	All D170, 190 Models - Interim Build Models Only
504060	Output Shaft Brg Kit	All D170, 190 Models - Current (NEW) Builds After Oct 2011
512894	Output Shaft Kit (shaft# 131536)	All D170, 190 Models
131095K	Pinion Nut Kit	Only D-Input & Rear-Pinion Models
504041	Pinion Bearing Spacer Kit	All D170, D190 and D/R590
504042	Pinion Bearing Spacer Kit	All R170, R190, S170, S190
504069	Ring Gear Bolt Kit	All Models
131008K	Seal & Nut Kit	Only D-Input & Rear-Pinion Models (contains the 134323 seal)
134323	Seal - Oil	Input Location
210737	Seal - Oil	Output Location
134323	Seal - Oil	R-Pinion
510870	Shift Fork & Spring Kit	All D170 Models
514142	Shift Fork & Spring Kit	All D190 Models
513349	Tool - Pinion Seal Driver Tool Kit	All Models
513061	Tool - Diff Bearing Adjustment Tool Kit	All Models
507162	U-Tube Breather Kit	All Models
513868	Wheel Diff Side Gear Kit - 46 Inv	All Models



SPICER®

Drivetrain Products

Axles
Driveshafts
Off-Highway Transmissions

PARISH®

Structural Products

Vehicle Frames
Engine Cradles

LONG®

Thermal Products

Transmission Oil Coolers
Engine Oil Coolers

VICTOR REINZ®

Sealing Products

Gaskets and Seals
Cylinder-Head Cover Modules
Thermal-Acoustic Protective Shielding

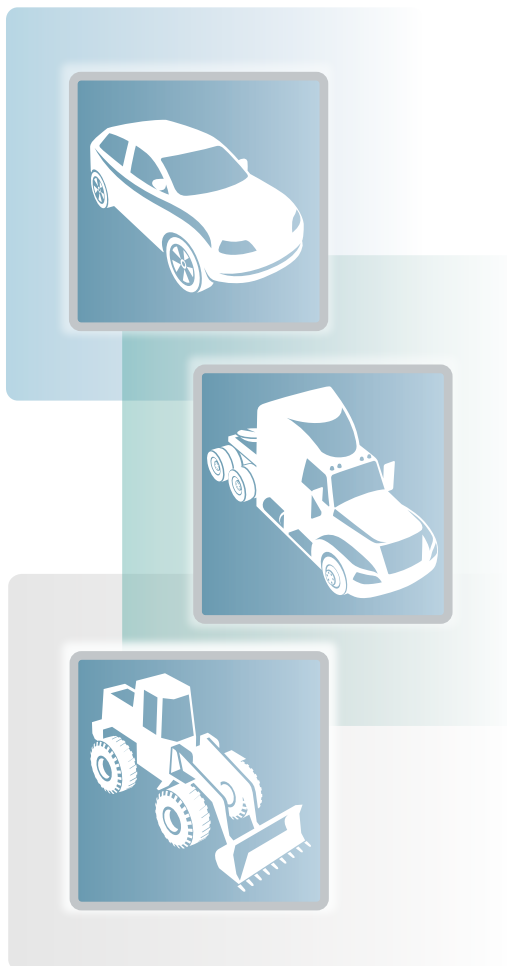

Dana Aftermarket Group
PO Box 321
Toledo, Ohio 43697-0321

Warehouse Distributor: 1.800.621.8084
OE Dealers: 1.877.777.5360

www.spicerparts.com

SPICER®

